

Table of Contents

1	Product Description	2
1.1	Mounting location.....	2
2	Technical Data	2
2.1	General.....	2
2.2	Hydraulic.....	2
2.3	Electrical.....	2
3	Ordering Information	3
3.1	Versions currently available.....	3
4	Installation	3
4.1	General remarks.....	3
4.2	Installation.....	3
4.3	Dimensions.....	4
5	Notes, Standards and Safety Requirements	4
5.1	General remarks.....	4
5.2	Standards.....	4
5.3	Safety Requirements.....	4
6	Accessories	4

1 Product Description

With directional control valves 4/3 or 4/2 double-acting consumers or piloting signals can be operated.

4/2: In the idle position, the consumer is enabled in one direction. In the activated position the consumer is operated in the other direction. The valves vary in the actuation (manual, electric or hydraulic), in the hydraulic connections and in the overlap position from the idle to the activated position.

4/3: In the center- position, the consumer usually is not activated. In the two activated positions the consumer is operated in one or the other direction. The valves vary by the actuation (manual, electric or hydraulic), by the hydraulic connections in the central position and the overlap positions from center-position to the activated positions.

1.1 Mounting location

Directional Control Valves 4/3 and 4/2 are to be flanged directly onto control valves or connected with special mounting plates.

2 Technical Data

2.1 General

Criterion	Unit	Value
Type		Directional spool valve
Maximum operating pressure	bar	Ports P, A, B = 350; Port T = 210
Weight	kg	4,8 (one solenoid), 6,3 (two solenoids)
Nominal Size		DIN NG10 / CETOP 05 / NFPA D05
Connection		
connection flange		DIN 24340 A10 / ISO 4401 / CETOP RP 121-H / NFPA D05
Installation position		any

2.2 Hydraulic

Criterion	Unit	Value
Hydraulic fluid		Mineral oil (HL, HLP) conforming with DIN 51524, other fluids upon request
Hydraulic fluid temperature range	°C	-25 ...+70
Ambient temperature:	°C	-25...+50
Viscosity range permitted	mm ² /s	2,8...400
Viscosity range recommended	mm ² /s	30 ...80
Contamination grade		Filtering conforming with NAS 1638, class 9, with minimum retention rate $\beta_{10} \geq 75$

2.3 Electrical

Criterion	Unit	Value
Duty cycle	%	100
Protection class according to DIN 40050		IP 65
Supply voltage	V	12 V = 24V=
Tolerance supply voltage	%	±10 ±10
Current consumption	A	3 1,5
Power consumption	W	36 36
Electrical connection		
Electrical connection		Connector as per EN 175301-803, solenoid type as per ISO 9461 (code W).
Minimum wire diameter	mm ²	3x1,5
Maximum Wire length	m	50

3 Ordering Information

3.1 Versions currently available

The versions listed below are available as standard. Further versions as part of the options given on the type code can be configured upon request.

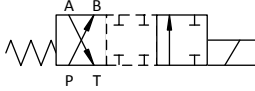
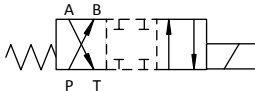
Part No.	Description		Pmax. (bar)	Code	VDC	special version
285.502.000.6	Directional Control Valve, NG10, S4/2		350	005	12	
285.501.000.6	Directional Control Valve, NG10, S4/2		350	020	12	



4 Installation

4.1 General remarks

- All installation and safety information from the machine manufacturer are to be observed.
- Only technically permitted changes are to be made on the machine.
- The user must ensure that the device is suitable for the respective application.
- Application exclusively for the range of application specified by the manufacturer.
- Before installation or dismantling, the hydraulic system is to be depressurized.
- Settings are to be made by qualified personnel only.
- Opening is only to be performed with the approval of the manufacturer, otherwise the warranty is invalidated.
- No responsibility is taken for the correctness of these connection recommendations, the functionality and the technical details of the machine must be checked.

4.2 Installation

- Observe the connections.
- Observe the strength category and torque (see appendix) of the fastening bolts.
- Do not damage seals and flange surface.
- The air must be exhausted from the hydraulic system.
- The space necessary to remove the plug per EN 175301-803, design type AF is at least 15 mm.
- The torque for the screw M3 of the plug has to be 0.5 to 0.6 Nm.

	
4x M6x40 - DIN912 12,9	13,2 Nm

4.3 Dimensions

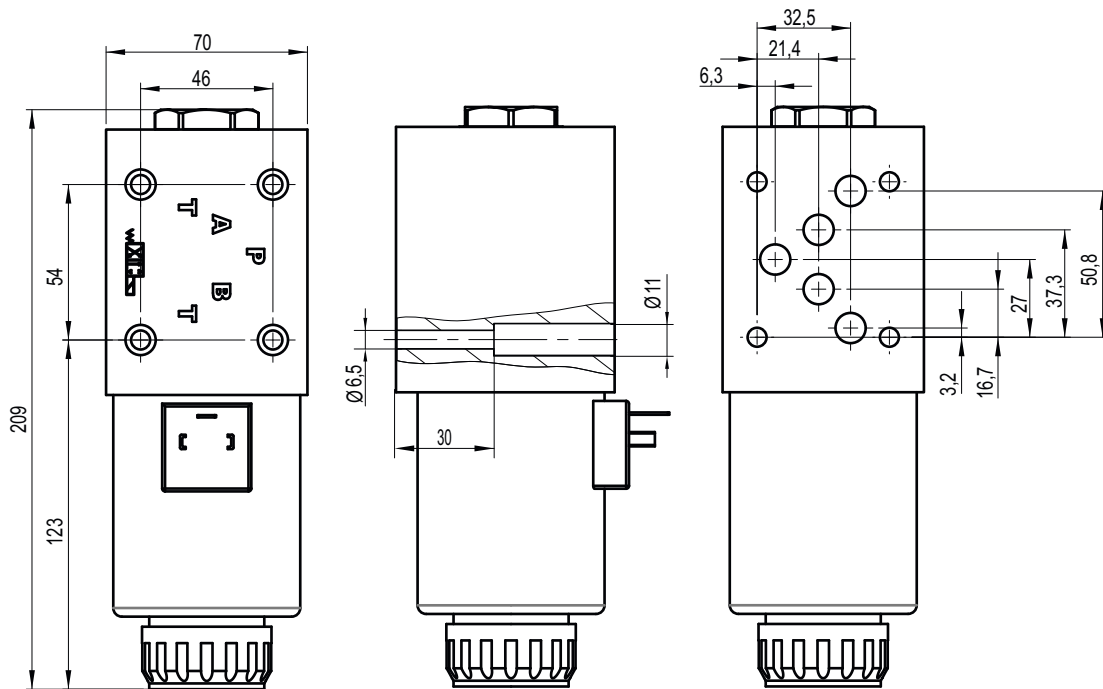

5 Notes, Standards and Safety Requirements

5.1 General remarks

- The views in drawings are shown in accordance with the European normal projection variant

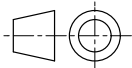

- A comma (,) is used as a decimal point in drawings
- All dimensions are given in mm

5.2 Standards

The following standards must be observed when installing and operating the valve:

- DIN EN ISO 13732-1:2008-12, Temperatures on accessible surfaces

5.3 Safety Requirements

- WESSEL-HYDRAULIK GmbH guarantees utilization of standard and proven safety principles in accordance with ISO 13849-2: 2003, Tables C.1 and C.2 for the construction of the valve described here.
- WESSEL-HYDRAULIK GmbH has a certified quality management system in accordance with DIN EN ISO 9001.
- 150 years may be assumed as MTTFd-value for the described product.
- Note: The user is therefore responsible for complying with the fundamental and proven safety principles according to ISO 13849-2: 2003, Tables C.1 and C.2 for the implementation and operation of the hydraulic component!

6 Accessories

- Angled plug ISO 4400, part No. 340.201.900.6 gray design
- Angled plug ISO 4400, part No. 340.202.900.6 black design