

Table of Contents

1	General Description	2
1.1	Applications.....	2
1.2	Mounting Location (Recommendation).....	2
1.3	Function.....	2
1.4	Characteristics.....	2
2	Technical Data	3
3	Ordering Information	4
3.1	Type Code.....	4
3.2	Currently available Versions.....	4
4	Description of Features according to Type Code	5
4.1	Feature 1: Design.....	5
4.2	Feature 2: Connection Ports.....	5
4.3	Feature 3: Inlet Volume Flow.....	5
4.4	Feature 4: Maximum Pressure.....	5
4.5	Feature 5: Activation.....	5
4.6	Feature 6: Hydraulicsystem.....	5
4.7	Feature 7: Output volume flow.....	5
4.8	Feature 8: Check Valve.....	5
5	Installation	6
5.1	General Instructions.....	6
5.2	Connection Proposal.....	6
5.3	Mounting: SAE - ports.....	6
5.4	Dimensions.....	7
6	Notes, Standards and Safety Instructions	8
6.1	General Instructions.....	8
6.2	Standards.....	8

1 General Description

Flow control valves of this product group are used to supply hydraulic consumers, such as hydraulic motors, hydraulic hammers, etc. with a controlled flow rate. This volume flow is divided from a main volume flow by means of the flow control valve. Valves of the variant 1D are in both the Open-Center- and Closed-Center-hydraulic systems installed in the line between pump and main control block, either directly on the pump or directly on the pump inlet of the main control block. A further Load-Sense-Valve for the additional function can be supplied from this valve with a priority flow. The priority valve is controlled by the Load-Sensing signal from the additional function. The priority valve itself controls the pump in a CC-system also with the consumer LS signal. A control of the pump in an OC-system is not necessary and is typically done automatically.

1.1 Applications

The flow control valve is used to divide the volume flow of the main pump in a priority flow to supply auxiliary consumers and a residual flow to supply the existing main functions in a construction machine.

1.2 Mounting Location (Recommendation)

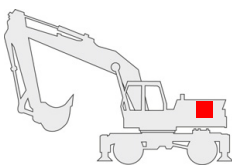

The flow control valve is installed in open-center and closed center systems between the main pump and the main control valve and the entire flow of the pump passes through this valve. The divided flow to additional consumers has priority over the main functions. The valve is either directly flanged to the pump or the pump inlet of the main control valve.

1.3 Function

At port P1, a priority volume flow is divided from the main flow of the pump (port P). The residual volume flow passes the lockable check valve to port Z and provides other consumers at the main control valve. The load signal for the attachment acts via the LS port of the priority valve on a pressure-reducing valve (LS-amplification), which influences the closing force of the check valve, thereby regulating the requested priority flow. The LS signal from the priority valve must be connected to the pump controller by means of a change-over valve or non-return valve (depending on main control) for a Close Center system.

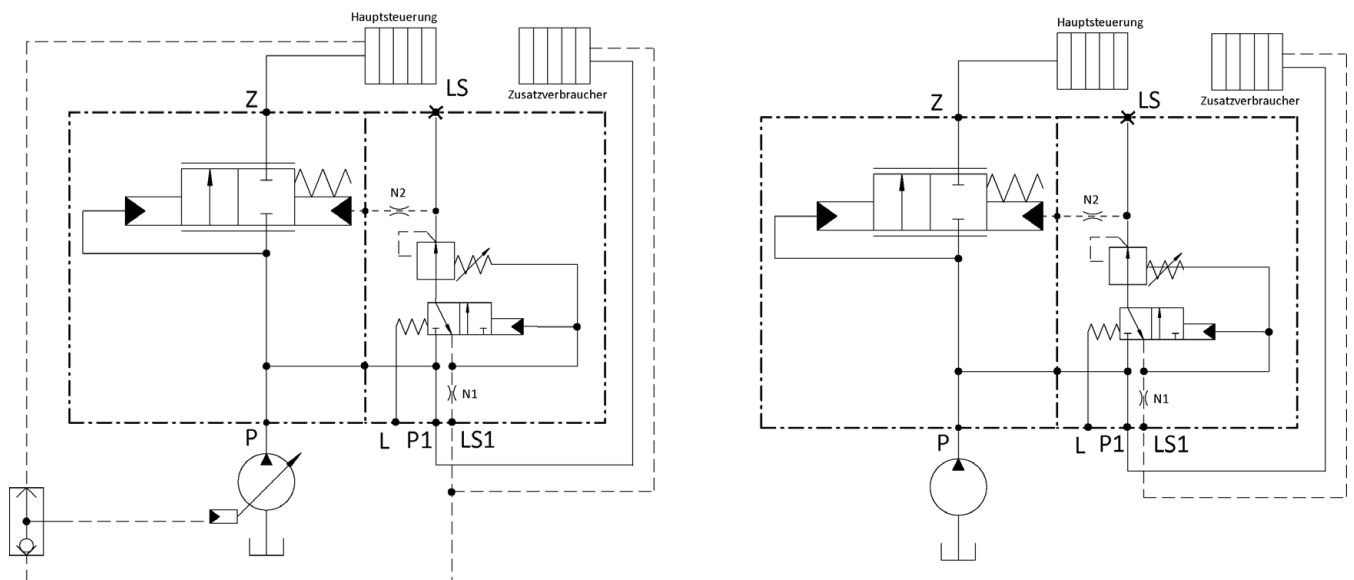

1.4 Characteristics

- Dividing of a partial volume flow with priority
- To be mounted directly on the pump or the pump inlet port of the main control valve
- Priority valve can supply Load-Sensing valves for additional consumers
- Low pressure loss for the main volume flow from the pump to the main control valve

2 Technical Data

Criterion	Unit	Value
Weight	kg	4,6
Maximum inlet pressure	bar	420 with SAE-fitting with bolts of quality 12.9 315 with SAE-fitting with bolts of quality 8.8
Maximum pressure at outlet port	bar	420 with SAE-fitting with bolts of quality 12.9 315 with SAE-fitting with bolts of quality 8.8
Maximum pressure at port T	bar	1 bar (recommended)
Maximum inlet volume flow	l/min	300 construction size SAE ¾" 400 construction size SAE 1" 600 construction size SAE 1¼"
Hydraulic fluid		Mineral oil (HL, HLP) conforming with DIN 51524, other fluids upon request
Hydraulic fluid temperature range	°C	-20 – +80
Ambient temperature:	°C	< +50
Viscosity range	mm ² /s	2.8 – 500
Contamination grade		Filtering conforming with NAS 1638, class 9, with minimum retention rate $\beta_{10} \geq 75$
Connection		Connection sizes
Port P		Code 62, ISO 6162
Port Z		Code 62, ISO 6162
Port P1		G 1", ISO 1179-1
Port LS, LS1		G ¾, ISO 1179
Port MP		G ¾, ISO 1179

3 Ordering Information

3.1 Type Code

FC1 00	1D 01	02	03	420 04	HYP0 05	00 06	999 07	00 08
00	Product group	flow control valves						FC1
01	Design	priority valve – directly flangeable						1D
02	Connection(s)	pump (P), main valve (Z)	SAE 3/4"- CODE 62				05C	
			SAE 1"- CODE 62				05E	
			SAE 1 1/4"- CODE 62				05G	
03	Inlet volume flow	construction size SAE 3/4"		300 l/min		300		
		construction size SAE 1"		400 l/min		400		
		construction size SAE 1 1/4"		600 l/min		600		
04	Maximum pressure	At ports P, P1 and Z		420 bar		420		
05	Activation	hydraulic proportional (LS-port)						HYP03B
06	Hydraulic System	independent of the hydraulic system						00
07	Output volume flow	automatically controlled						999
08	Check valve, throttle check valve	without check valve						00

XX – fixed features XXX – customer selectable features ■ available ○ not available

Some theoretical configurations might be not feasible for technical reasons. For relating questions please ask for our advice.

3.2 Currently available Versions

The versions listed below are available standard-versions. Further versions in the range of the above mentioned features are available on request.

00	01	02	03	04	05	06	07	08	Designation	Part No.
FC1	1D	05C	300	420	HYP0	00	999	00	Flow Control Valve, direct flanged, SAE 3/4"	436.063.402.9
FC1	1D	05E	400	420	HYP0	00	999	00	Flow Control Valve, direct flanged, SAE 1"	438.063.403.9
FC1	1D	05G	600	420	HYP0	00	999	00	Flow Control Valve, direct flanged, SAE 1 1/4"	438.063.405.9

4 Description of Features according to Type Code

4.1 Feature 1: Design

Directly flangeable onto the pump or the pump inlet of the main control valve

4.2 Feature 2: Connection Ports

The input and the main output port are configured as SAE flange. The port for the divided priority flow to the additional consumer is designed as a threaded connection (G1).

4.3 Feature 3: Inlet Volume Flow

The maximum input flow rate is dependent on the size of the valve.

ΔP (bar)

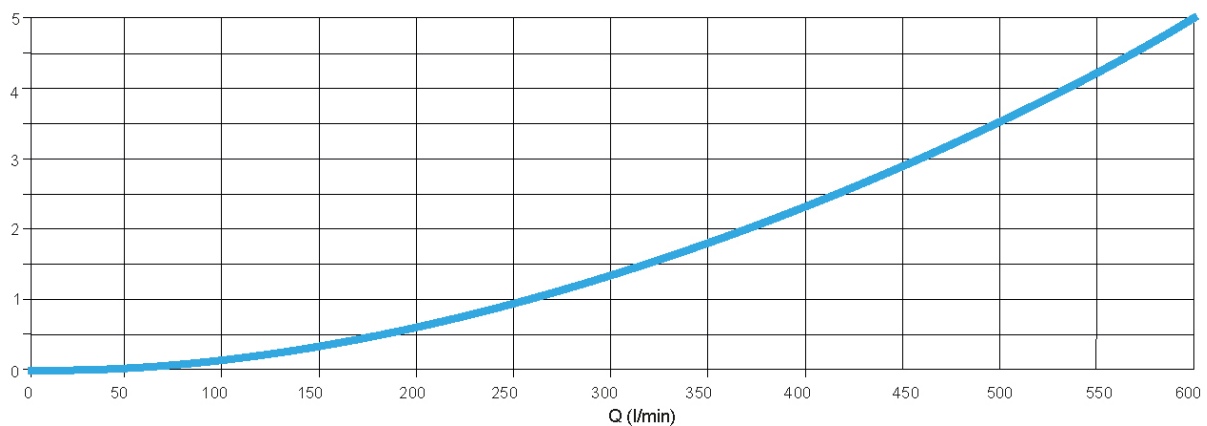

4.4 Feature 4: Maximum Pressure

The permissible maximum pressure at the main terminals (P, P') should not exceed the following values:

- 420 bar with SAE-fittings with bolts of quality 12.9
- 315 bar with SAE-fittings with bolts of quality 8.8

4.5 Feature 5: Activation

The valve is controlled by the Load-Sensing signal of the consumer at port LS. The signal depends on the requested volume flow of the attachment. A possible loss of pressure in the pipe from the priority valve to the consumer can be compensated by the LS amplification (internal, adjustable pressure reducing valve).

4.6 Feature 6: Hydraulicsystem

The valve can be used in open-center, as well as in closed-center hydraulic systems. When used in a closed-center hydraulic system the pump must also be controlled by the LS-signal generated by the consumer.

4.7 Feature 7: Output volume flow

The maximum output flow depends on the size of the valve. The maximum output flow rate corresponds to the maximum input flow.

4.8 Feature 8: Check Valve

Valves of type 1D do not need a check valve or throttling check valve at its output terminal

5 Installation

5.1 General Instructions

- Observe all installation and safety information of the construction machine manufacturer.
- Only technically permitted changes are to be made on the construction machine.
- The user has to ensure that the device is suitable for the respective application.
- Application exclusively for the range of application specified by the manufacturer.
- Before installation or dismantling, the hydraulic system is to be depressurized.
- Settings are to be made by qualified personnel only.
- May only be opened with the approval of the manufacturer, otherwise the warranty is invalidated.
- The included connection recommendations are not guaranteed. The functionality and the technical specifications of the construction machine must be checked.

NOTE:

When the valve is initially put into operation, noises may occur. These noises are caused by air in the valve and disappear shortly after a few load changes. No special measures are required.

5.2 Connection Proposal

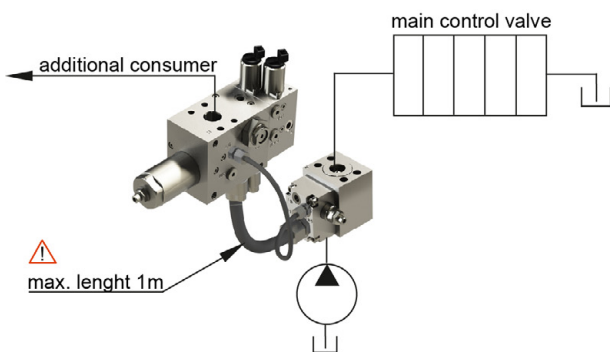

Installation: Open-Center Hydraulic System

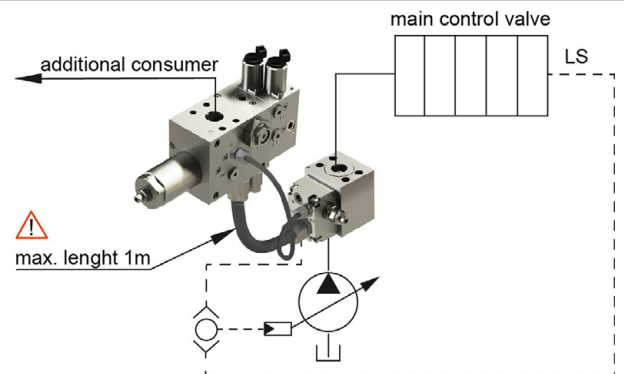

Installation: Closed-Center Hydraulic System

5.3 Mounting: SAE - ports

- Observe the connection labels
- Observe the strength category and torsional torque of the clamp bolts
- Do not damage seals and flange surface
- The air must be exhausted from the hydraulic system
- Observe the recommended installation screws

Port size	Thread (A)	Strength Class	tightening torque (Nm)	C (mm)	B (mm)
SAE 3/4"	M10	10.9	70	with sealing plate 99	mind. 16,5
DIN ISO 6162-2:2012				without sealing plate 89	
SAE 1"	M12	10.9	130	with sealing plate 99	mind. 21,5
DIN ISO 6162-2:2012				without sealing plate 89	
SAE 1 1/4"	M14	8.8	150	with sealing plate 104,8	mind. 23,5
DIN ISO 6162-2011				without sealing plate 94,8	

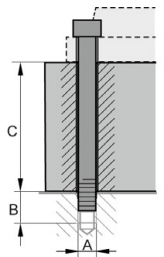

Attention: Tightening torques must be observed. Torque wrench needed.

5.4 Dimensions

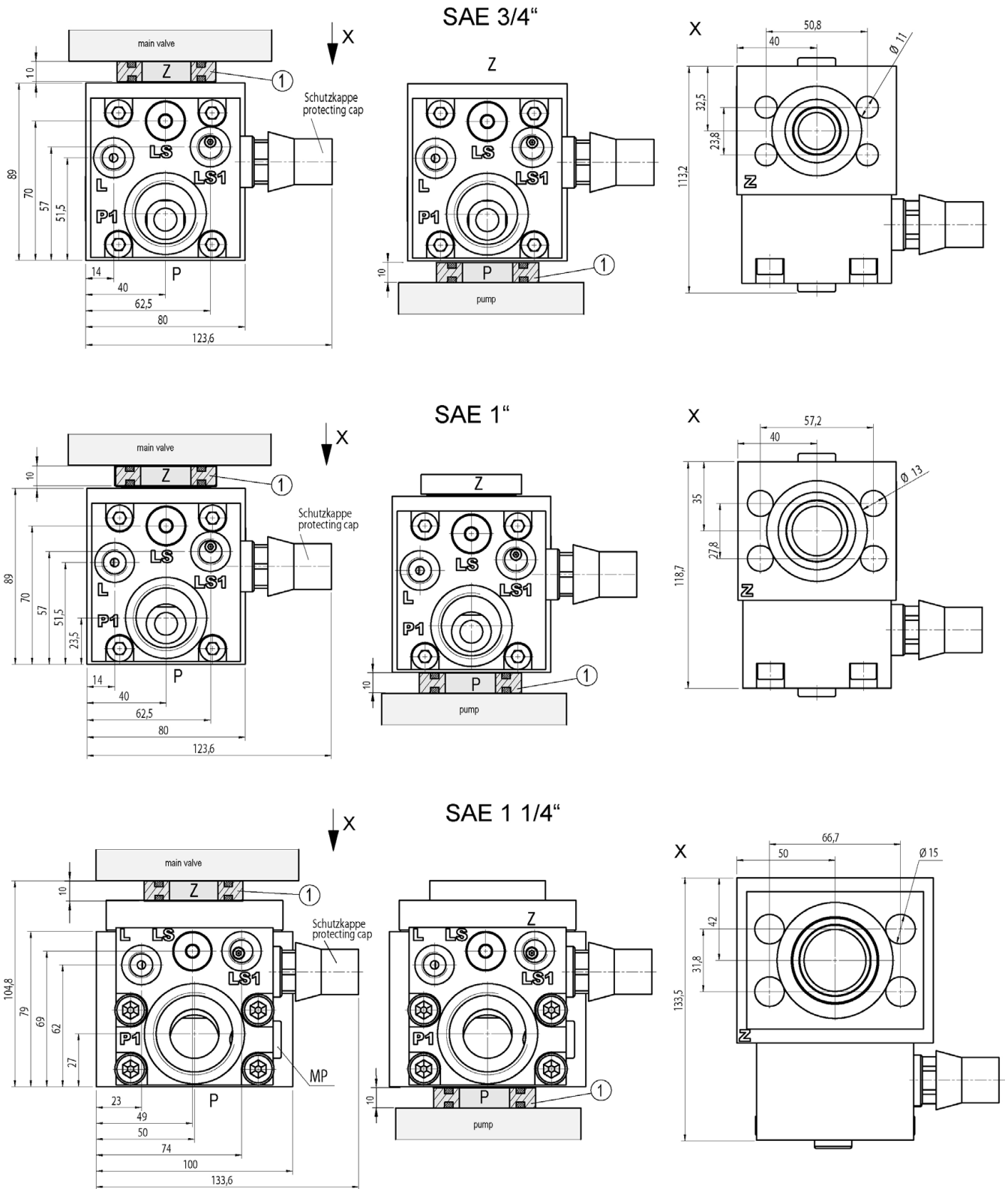

6 Notes, Standards and Safety Instructions

6.1 General Instructions

- The views in drawings are shown in accordance with the European normal projection variant

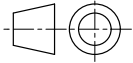

- A comma (,) is used as a decimal point in drawings
- All dimensions are given in mm

6.2 Standards

The following standards must be observed when installing and operating the valve:

- DIN EN ISO 13732-1:2008-12, Temperatures on accessible surfaces