

\* Maße in Fertigungszeichnung angeben!  
 \* Specify dimensions in production drawing!

Bore diameter after fitting  
 max. 0.5 mm smaller  
 Dimensions in millimeters  
 workpiece edge DIN 6784  
 undimensioned workpiece edge -0.3  
 undimensioned inner edge +0.2

|         |             |
|---------|-------------|
|         |             |
| 15 H7   | +0.018<br>0 |
| fitting | diameter    |

Hole

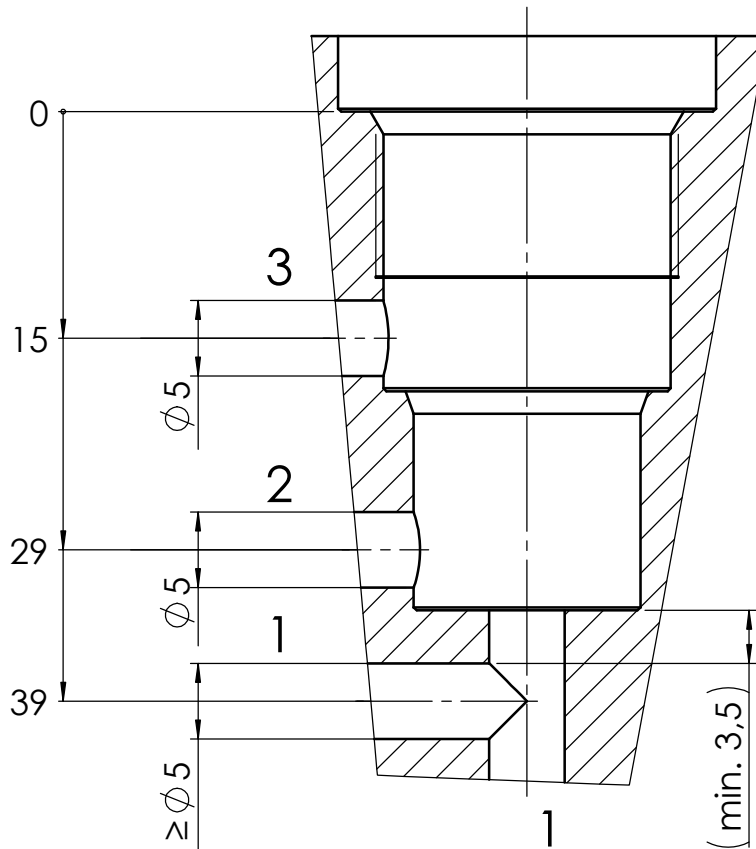

we engineer your progress

Dimensions in millimeters