

we engineer your progress

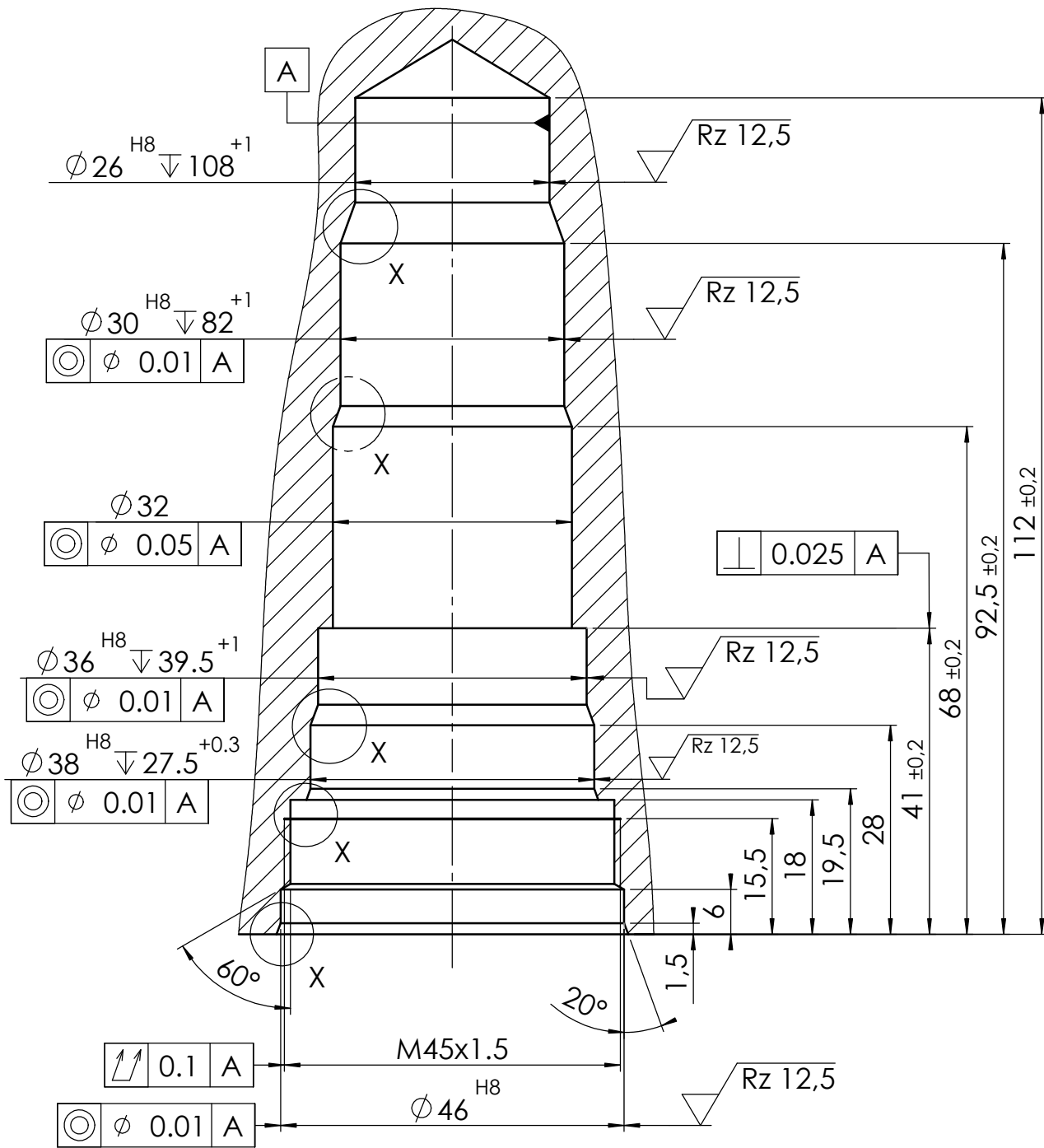

46 H8	+0.039 0
38 H8	+0.039 0
36 H8	+0.039 0
30 H8	+0.033 0
26 H8	+0.033 0
fitting diameter	

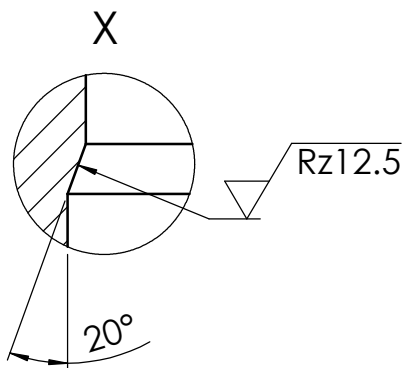

Bore diameter after fitting
max. 0.5 mm smaller.

Dimensions in millimeters

workpiece edge DIN 6784
undimensioned workpiece edge -0.3
undimensioned inner edge +0.2

