

we engineer your progress

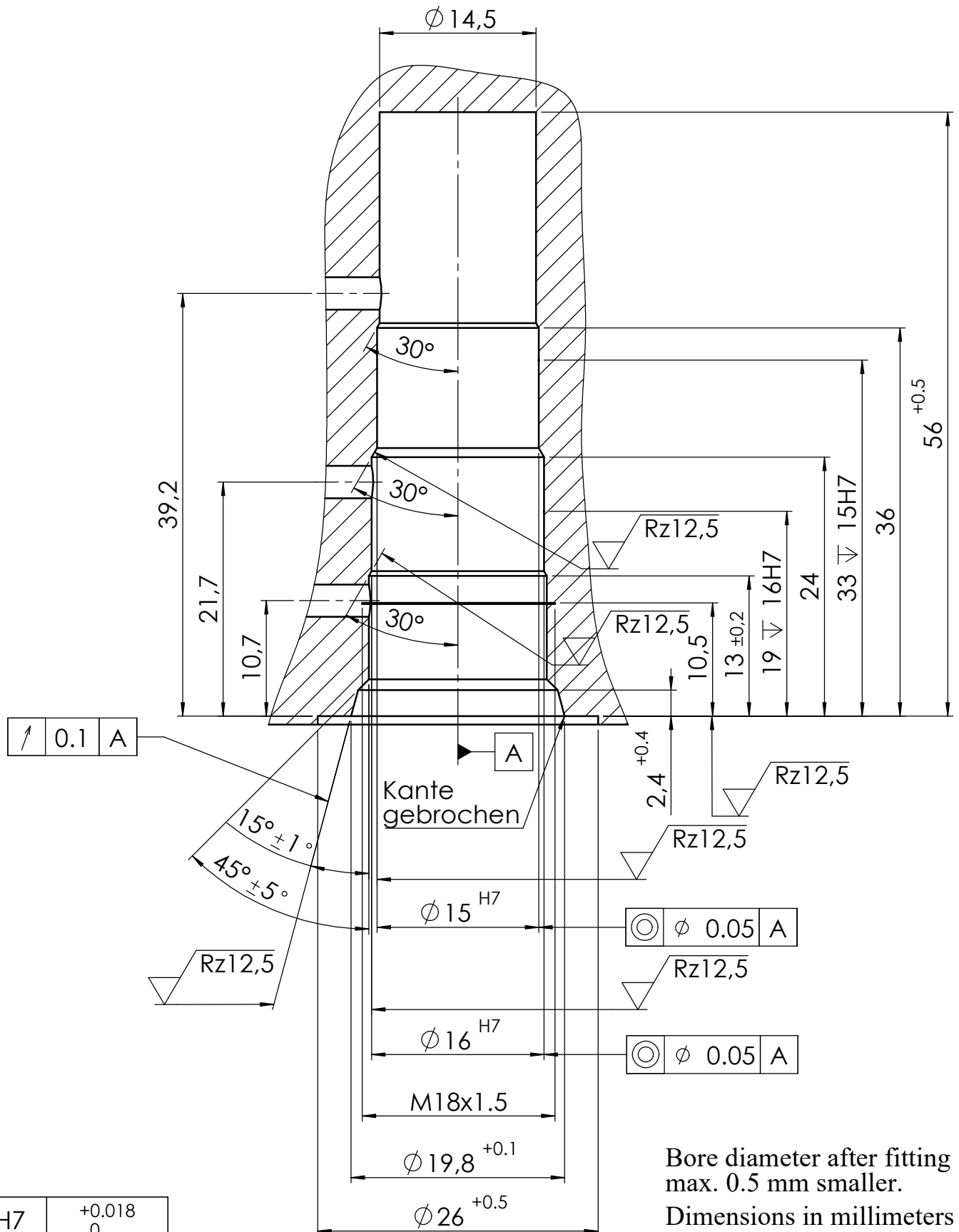

Bore diameter after fitting
max. 0.5 mm smaller.

Dimensions in millimeters

workpiece edge DIN 6784
undimensioned workpiece edge -0.3
undimensioned inner edge +0.2

16 H7	+0.018 0
15 H7	+0.018 0
fitting	diameter