



## Table of Content

<b>1</b>	<b>General Description</b> .....	<b>2</b>
<b>2</b>	<b>Block Diagram of the WESSEL Tool Control <sup>plus</sup></b> .....	<b>2</b>
2.1	Complete Unit .....	2
<b>3</b>	<b>Technical Data</b> .....	<b>3</b>
<b>4</b>	<b>Electrical Connection</b> .....	<b>4</b>
4.1	Installation Description .....	4
4.2	Connection the Programming cable .....	4
4.3	Pin-outs of the Plug-In Connector S1 .....	4
<b>5</b>	<b>Dimensions</b> .....	<b>5</b>
<b>6</b>	<b>Installation</b> .....	<b>6</b>
6.1	Connecting the power supply .....	6
6.2	Connecting a solenoid to an output .....	6
<b>7</b>	<b>Error codes</b> .....	<b>6</b>
7.1	Valve error codes .....	6
7.2	Analog input error codes .....	7
7.3	Digital input error codes .....	7
7.4	Reset an error .....	7
<b>8</b>	<b>Hinweise, Notes, Standards and Safety Requirements</b> .....	<b>8</b>
8.1	General remarks .....	8
<b>9</b>	<b>attachements</b> .....	<b>8</b>

## 1 General Description

WESSEL Tool Control <sup>plus</sup> can be used in construction machines for proportional control of additional functions or to expand existing functionalities. It is mainly used if attachment tools are changed frequently on the construction machine and the hydraulic data and functions on the individual tools have to be adapted each time.

The service technician programs the WESSEL Tool Control <sup>plus</sup> according to the data and desired functions of the individually used attachment tool. The operator can simply press a button to change the previously programmed tool and control functions using WESSEL Tool Control <sup>plus</sup>.

WESSEL Tool Control <sup>plus</sup> is a programmable electronic controller for operation of up to six proportional solenoids. The outputs can be linked with the signals from four electrical-proportional inputs. The operator can choose from up to sixteen different profiles (data and functions for attachment tools), which define the connections of the inputs and the minimum and maximum current values on the outputs.

WESSEL Tool Control <sup>plus</sup> can control valves that are actuated with standard proportional solenoids or switching solenoids. The input signals can be applied by Joystick, Potentiometer, simple switch, relay or sensors (e.g. pressure sensor). The inputs and outputs can be connected with one another in almost any way with simple programming.

## 2 Block Diagram of the WESSEL Tool Control <sup>plus</sup>

### 2.1 Complete Unit

The WESSEL Tool Control <sup>plus</sup> is a user-friendly controller, encased in a compact housing with two plug-in connections. The inputs, the outputs and the power supply are connected via plug-in connector S1. The optional PC interface can be connected at the plug-in connection S2.

The device is equipped with a membrane keypad with six keys, of which two keys are for operation and the other four are for programming. The device also has an 80 character LCD display, on which the status of the outputs is displayed and the service technician is guided through the set-up and programming.

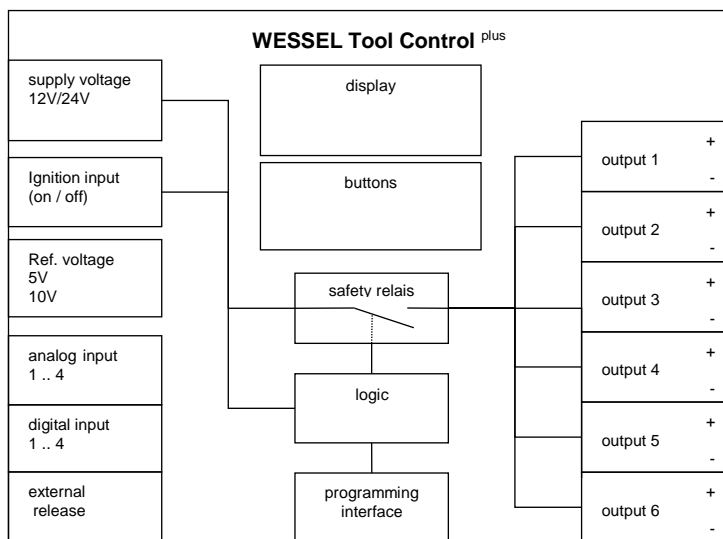

### 3 Technical Data

Criteria	Value
<b>Common Data</b>	
Housing	aluminum (black)
Protection class	IP65
Connector 1 (S1)	42 pol. AMP (1-967281-1)
Connector 2 (S2)	3 pol. 3,5mm stereo jack (serial interface with 5V TTL level)
Dimensions	170mm x 145mm x 55mm (B x H x T)
Weight	0,82 kg
<b>Environmental conditions</b>	
Operating voltage	12V +/- 15%, 24V +/- 15%
EMC	ISO 13766
Operating temperature	DIN EN 60068-2-14: -25°C -.. +70°C
Vibration	DIN EN 60068-2-6
<b>Inputs / outputs</b>	
Reference voltage	5V(±0.25V) Reference voltage for analog signal encoder (approx. 50mA) 10V(±0.4V) Reference voltage for analog signal encoder (approx. 50mA)
4 analog inputs	0..5V, 0..10V, 0..20mA, 4..20mA
4 digital inputs	logic 0 < 2V, logic1 >10V
1 external enable	logic 0 < 2V, logic 1 >10V
6 PWM outputs	12V / max. 2A, 24V / max. 1A
1 CAN interface	Communication interface
1 programming interface	programming interface

## 4 Electrical Connection

### 4.1 Installation Description



A total of 42 cables can be connected with the WESSEL Tool Control <sup>plus</sup> through the plug-in connector S1, of which 6 are reserved and are not to be connected.

The supply voltage can be 12V or 24V, which is automatically detected by the WESSEL Tool Control <sup>plus</sup> and must be attached on each of pins 1, 15, 29 as positive pole and 14, 28, 42 as negative pole. The required minimum wire cross-section is 0.75mm<sup>2</sup>.

**Each of the three plug-in contacts must be connected with a cable for the supply voltage + (PIN 1, 15, 29) as well as for 0 Volt (Pin 14, 28, 42).**

To power on the WESSEL Tool Control <sup>plus</sup> it's necessary to connect the ignition input (VinZ+) to the ignition of the construction machine.

The PIN-outs for the analog inputs and outputs are shown in the table under 4.3.

When connecting the power supply of the valves, make sure that they are connected with OUT+ and OUT-, according to the predefined outputs. The vehicle ground is not to be used as a return line!

Important Note: If the supply voltage (Vin+) is connected to the ignition of the construction machine, make sure that the maximum current possible is 15A. The power supply may have to be done through a relay.

### 4.2 Connection the Programming cable

The connector S2 is behind the DAE (pressure compensation element).

### 4.3 Pin-outs of the Plug-In Connector S1

Pin	Designation	Comment	Pin	Designation	Comment
1	Vin+	Supply voltage 12V/24V.	22	ANIN 4	Analog input 4
2	OUT 2+	Plus valve 2	23	DIGIN 4	Digital input 4
3	OUT 1-	Minus valve 1	24	DIGIN 3	Digital input 3
4	OUT 2-	Minus valve 2	25	DIGIN 2	Digital input 2
5	OUT 1+	Plus valve 1	26	DIGIN 1	Digital input 1
6	OUT 4+	Plus valve 4	27	Ext.Enable	External enable
7	OUT 3-	Minus valve 3	28	Vin-	Vehicle ground 0V
8	OUT 4-	Minus valve 4	29	Vin+	Supply voltage 12V/24V.
9	OUT 3+	Plus valve 3	30	CAN_L	CAN-Low
10	OUT 6+	Plus valve 6	31	GND	GND for reference voltage
11	OUT 5-	Minus valve 5	32	GND	GND for reference voltage
12	OUT 6-	Minus valve 6	33	GND	GND for reference voltage
13	OUT 5+	Plus valve 5	34	VinZ+	Ignition input (12V / 24V)
14	Vin-	Vehicle ground 0V	35	-	Reserved
15	Vin+	Supply voltage 12V/24V.	36	-	Reserved
16	CAN_H	CAN-High	37	GND	GND for reference
17	+10V ext.	10V reference voltage (max50mA)	38	-	Reserved
18	+ 5V ext.	5V reference voltage (max. 50mA)	39	-	Reserved
19	ANIN 1	Analog Input 1	40	-	Reserved
20	ANIN 2	Analog Input 2	41	-	Reserved
21	ANIN 3	Analog Input 3	42	Vin-	Vehicle ground 0V



Pin-outs of the Plug-In Connector S1

**5 Dimensions**

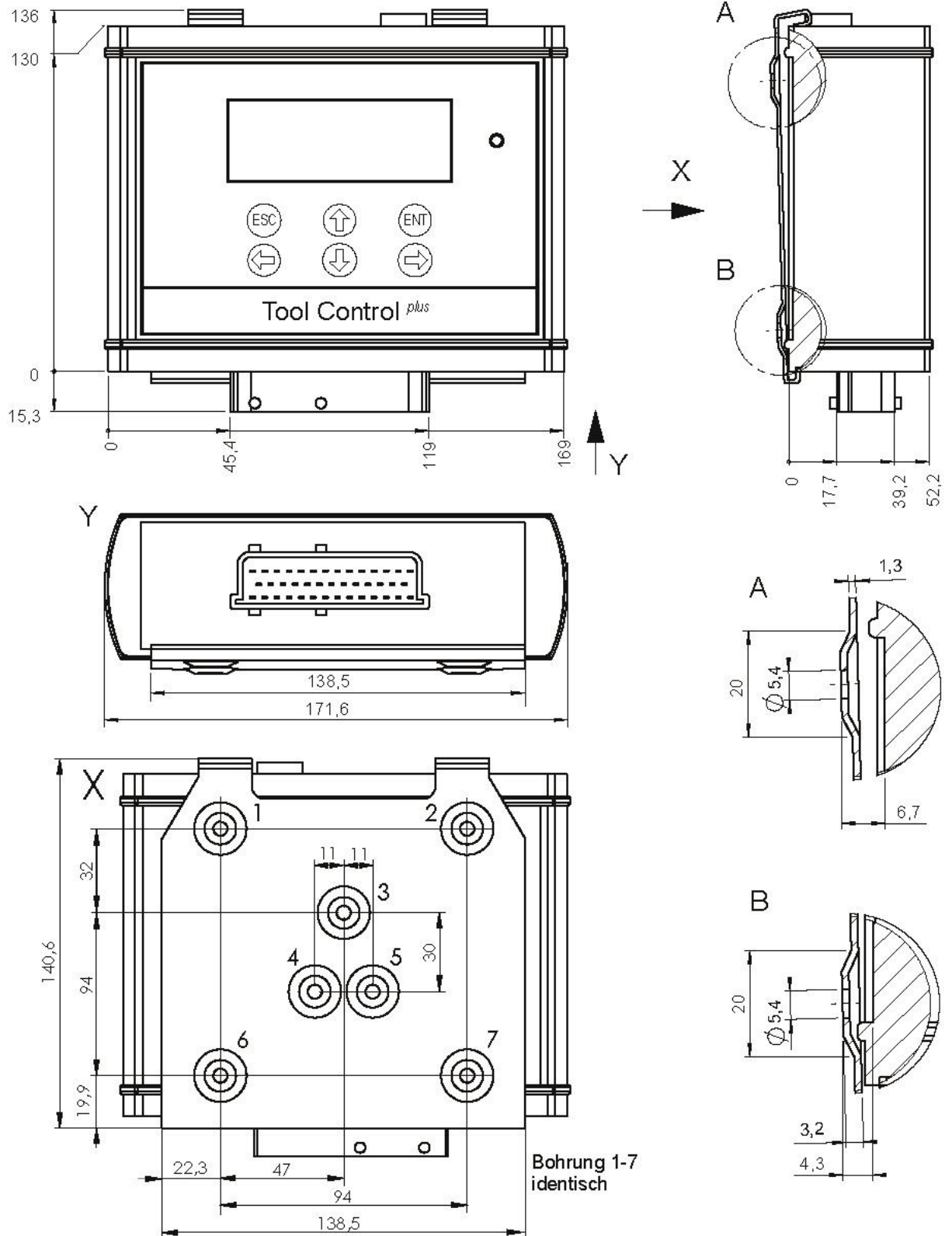

## 6 Installation

### 6.1 Connecting the power supply

The following diagram shows, how to connect the power supply to the WTC+, including the necessary fuses. The Vin+ fuse must not exceed a value of 15A. If the current consumption is lower, it is recommended to lower the fuse value also.

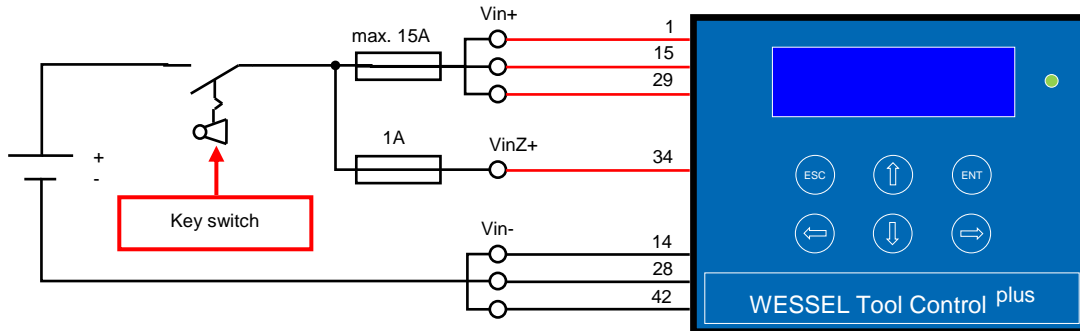

### 6.2 Connecting a solenoid to an output

Connecting a solenoid to output OUT1:

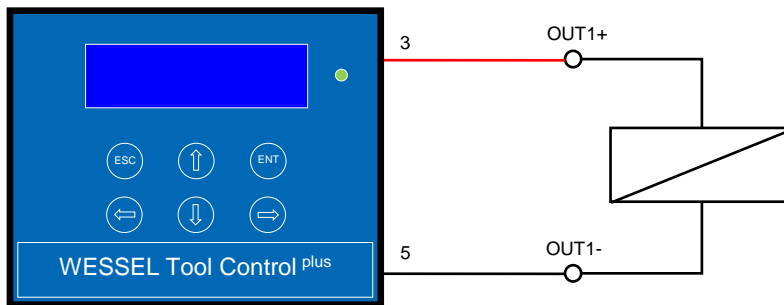

## 7 Error codes

### 7.1 Valve error codes

An error code will be displayed behind the valve symbol, or in the status row with „Err Vx“. In this case, the “X” means the valve number.

Code	Description	Remedial action
1	Current error (Current flow without demand, or no current on demand)	<ul style="list-style-type: none"> <li>Check pin connections.</li> <li>Check for cable fault or shorted cable.</li> </ul>
2	Controller range error	<ul style="list-style-type: none"> <li>Check for cable fault.</li> <li>Operates the valve in power range?</li> </ul>
3	Combination of error 1 & 2	See error code 1 & 2.
4	Unused.	
5	Unused.	
6	Unused.	
7	Unused.	
8	Shorted cable (+24V or OUT+ to OUT-).	<ul style="list-style-type: none"> <li>Check pin connections.</li> <li>Check for shorted cable.</li> </ul>
9	Combination of error 1 & 8.	See error code 1 & 8.
A	Combination of error 2 & 8.	See error code 2 & 8.
B	Combination of error 1, 2 & 8.	See error code 1, 2 & 8.
C	Unused.	
D	Unused.	
E	Unused.	

## 7.2 Analog input error codes

An error code will be displayed in the status row with „AlnX=Y“. In this case „X“ means the analog input number and „Y“ means error code. Only the input with the highest number will be displayed, independent from another possible errors. Error codes from digital inputs will be displayed before error codes from analog inputs.

Code	Description
1	Cable fault (signal < 2.5% of final value, or < 2mA if 4..20mA input is selected)
2	Cable shorted (signal > final value – 2.5%)
3	Over voltage (signal > 5,4V; only if 0..5V input is selected)
4	Calibration error(the calibration values aren't plausibel)
5	Difference for complementary input to high(the difference between both signals is > 10% of the final value)
6	Invailld configuration for complementary input (Only 0..5V/0..10V + Joystick valid)
7	Power on guard (Only at power on: An input signal is present)

### 7.2.1 Activation of the cable fault detection

Cable shorted detection will be activated after completion of the calibration procedure automatically as long as the calibration values are in a value range.

Input signal	Lower value	Upper value
0..5V	0,25V	4,75V
0..10V	0,5V	9,5V
0..20mA	1mA	19mA
4..20mA	2mA	19mA

### 7.2.2 Trigger values

To trigger an error code for cable break the signal must fall below shorted cable error the signal must exceed the maximum value.

Input signal	Lower value	Upper value
0..5V	0,12V	4,88V
0..10V	0,25V	9,75V
0..20mA	0,5mA	19,5mA
4..20mA	2mA	19,5mA

## 7.3 Digital input error codes

An error code will be displayed in the status row with „AlnX=Y“. In this case „X“ mean the digital input number and „Y“ means error code. Only the input with the highest number will be displayed, independent from another possible errors. Error codes from digital inputs will be displayed before error codes from analog inputs.

Code	Beschreibung
7	Power on guard (Only at power on: An input signal is present)

## 7.4 Reset an error

In order to get the device back in operational mode, solve the problem and acknowledge the error code. There are multiple ways to acknowledge an error. The first is to press the left and the right arrow keys simultaneously for at least 2 seconds. The second way is to use the external release. If the external release is activated, set it back to off to acknowledge the error. The last way is to power off the device. This is the only way to acknowledge the analog or digital input error code 7 (power on guard).

## 8 Hinweise, Notes, Standards and Safety Requirements

### 8.1 General remarks

- The views in drawings are shown in accordance with the European normal projection variant

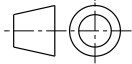

- A comma ( , ) is used as a decimal point in drawings
- All dimensions are given in mm

## 9 attachements

Programming the WESSEL Tool Control plus via a PC / notebook requires a programming cable and software. Both are not included with the WESSEL Tool Control plus scope of delivery

- The software can be downloaded from the homepage <https://www.wessel-hydraulik.de/downloads/>
- The programming cable can be ordered under Ident No. 000.310.024.9
- The connecting cable can be ordered under Ident No. 340.160.900.6





*we engineer your progress*

**CTR-TC2**  
**WESSEL Tool Control plus**