

Table of Contents

1	Product Description	2
1.1	Application	2
1.2	Mounting location (Recommendation)	2
2	Function	2
2.1	Characteristics	2
3	Technical Data	2
4	Ordering Information	3
5	Description of Characteristics in Accordance with Type Code	4
5.1	Variant	4
5.2	Connections	4
5.3	Input volume flow	5
5.4	Maximum permissible pressure	5
5.5	Actuation	5
5.6	Hydraulic system	5
5.7	Output volume flow	5
5.8	Check valve, throttling check valve	Fehler! Textmarke nicht definiert.
6	Installation	6
6.1	General remarks	6
6.2	Connection suggestion	6
6.3	Installation - Space	6
6.4	Setting the output flow rate	7
6.5	Setting the pressure relief for the attachment	7
6.6	Abmessungen	Fehler! Textmarke nicht definiert.
7	Notes, standards and safety requirements	9
7.1	General remarks	9
7.2	Standards	9
8	Accessories	9

1 Product Description

The flow control valve allows the operation of two-way consumers (rotary motors for shears and grippers, tilting buckets, sweeper brushes) on constructions machines that are not equipped for them.
The attachment can be used simultaneously in conjunction with normal construction machine functions

1.1 Application

The flow control valve is used to control functions which only require a low flow rate, it is designed for dividing a small priority flow from the main pump flow.

1.2 Mounting location (Recommendation)

The flow control valve is normally installed close to the hydraulic pump of which the partial flow for the additional consumer is divided from.

2 Function

The flow control valve consists of an inlet pressure compensator, a 4/3 way-valve and a pressure valve unit.

All versions of the flow control valve split the input flow into a priority flow for operating an attachment and a residual flow for normal machine functions.

Concerning the maximum through volume flow (P → A1) two variants are available:

The design with SAE 3/4" connections (P, A1) can be used for flow amounts of up to 300 l/min, while SAE 1" connections (P, A1) are suitable for flows of up to 400 l/min. Depending on the chosen activation method the valves can be operated electrical or hydraulic, switching or proportional.

The switching versions allow an outlet volume flow of 10-60 l/min. The proportional versions allow an outlet volume flow of 10-40 l/min.

The limitation of the volume flow available for the consumer is done mechanically in the inlet assembly (pressure compensator). The switching variants route this volume flow via the 4/3 directional valve completely to the consumer. The proportional version routes the volume flow via the 4/3 directional valve proportionally to the consumer.

The volume flow in the electrical-proportional versions is controlled with the electrical current into the control solenoids. In order to set the volume flow very accurately, the use of a PWM-controlled current is recommended. The control solenoids can also be actuated by switching the voltage without current control.

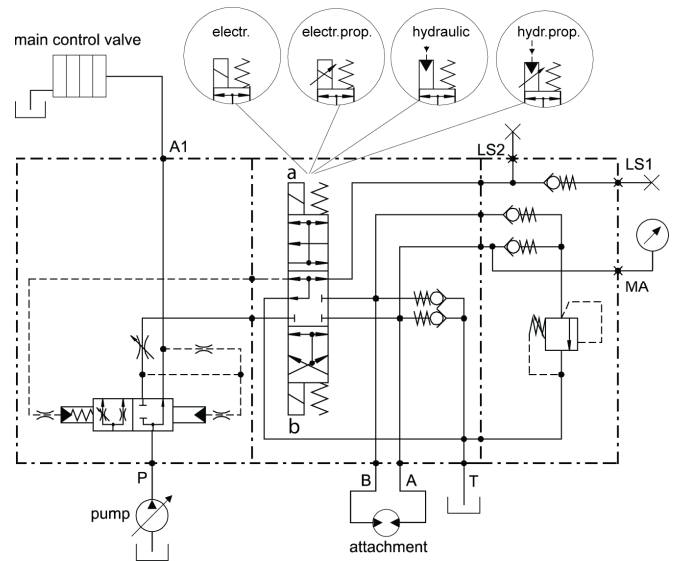

2.1 Characteristics

- Compatible with all standard hydraulic systems, preferably Open-Center-Systems
- Pressure protection of consumer ports
- Simple expansion of a hydraulic system for attachments with low flow requirements
- Integrated input valves for both attachment connections
- Controllable electrically or hydraulically, switchable or proportionally
- Stable flow control valve operation with input pressure compensator

3 Technical Data

Criteria	Unit	Value, applicable to all versions
Installation position		Any

Weight	kg	Approx. 14
Maximum input pressure (P, A)	bar	400
Adjustable attachment pressure	bar	50-320, factory setting 200
Plant-preset output flow rate	l/min	35 (switchable versions); no preset for proportional versions
Output flow rate accuracy	%	± 8
Maximum recommended tank pressure (T)	bar	approx. 5 (suction valve)
Maximum input flow rate (P)	l/min	SAE ¾" up to 300 l/min, SAE 1" up to 400 l/min
Maximum outlet flow rate (A, B)	l/min	60 switching, 40 proportional
Hydraulic fluid		Mineral oil (HL, HLP) conforming with DIN 51524, other fluids upon request
Hydraulic fluid pressure range	°C	-20 to +80
Ambient temperature	°C	< +50
Viscosity range	mm ² /s	2.8 - 500
Contamination grade		Filtering conforming with NAS 1638, class 9, with minimum retention rate $\beta_{10} \geq 75$
Proportional operated version		
Supply voltage prop. version	VDC	12 or 24
Control	Hz	Controlled flow with PWM frequency 100 Hz
Resistor R20	Ohm	19.2 (at 24 VDC); 5 (at 12 VDC)
Flow limit Ig:	A	0.8 (at 24 VDC); 1.6 (at 12 VDC)
Solenoid switch duty cycle	%	100
DIN 40050 protection class:		IP 65
Current supply		Device connector / ISO 4400 angle connector or AMP Junior Timer connector
Switchable version		
Supply voltage switching version	VDC	12 or 24
Voltage tolerances	%	± 10
Solenoid switch power consumption	W	33
Solenoid switch flow rate consumption	A	2.9 at 12 VDC, 1.4 at 24 VDC
Solenoid switch duty cycle	%	100
DIN 40050 protection class:		IP 65
Electrical connection		Device connector / ISO 4400 angle connector or AMP Junior Timer connector
Hydraulic operated version		
Maximum piloting pressure	bar	min. 25 – max.50
Piloting pressure 100% piloted	bar	25

4 Ordering Information

FC2	1N			320		OC		
00	01	02	03	04	05	06	07	08
00	Product group		Flow control valve for dual-acting consumers					00

01	Design	4/3-way valve for open center systems	01	1N
02	Connection(s)	SAE 1", ISO 6162-2, CODE 62, M12	02	05E
		SAE 3/4", ISO 6162-2, CODE 62, M10		05C
03	Inlet Volumeflow	SAE 3/4" 300 l/min CODE 62	03	300
		SAE 1" 400 l/min CODE 62		400
04	Maximum pressure	320 bar	04	320
05	Hydraulic System Output Flow	Electrical switching 12 VDC – ISO 4400 angle plug connection		12S001
		Electrical switching 24 VDC – ISO 4400 angle plug connection		24S001
		Electrical proportional 12 VDC – ISO 4400 angle plug connection		12P001
		Electrical proportional 24 VDC – ISO 4400 angle plug connection		24P001
		Electrical switching 12 VDC – connection via Junior Timer plug		12S002
		Electrical switching 24 VDC – connection via Junior Timer plug		24S002
		Electrical switching 12 VDC – connection via Deutsch Stecker		12S003
		Electrical switching 24 VDC – connection via Deutsch Stecker		24S003
		Electrical proportional 12 VDC – connection via Junior Timer plug		12P002
		Electrical proportional 24 VDC – connection via Junior Timer plug		24P002
		Hydraulic switching – VST connection G 3/4" ISO 1179-1		HYS03B
		Hydraulic proportional – VST connection G 3/4" ISO 1179-1		HYP03B
06	Product group	switched; Qmax = 40 l/min; mechanically limited		S040L
		switched; Qmax = 40 l/min; not mechanically limited		S040N
		proportional; Qmax = 40 l/min; mechanically limited		P040L
		proportional; Qmax = 40 l/min; not mechanically limited		P040N
		switched; Qmax = 50 l/min; mechanically limited		S050L
		switched; Qmax = 50 l/min; not mechanically limited		S050N
		proportional; Qmax = 50 l/min; mechanically limited		P050L
		proportional; Qmax = 50 l/min; not mechanically limited		P050N
		switched; Qmax = 60 l/min; mechanically limited		S060L
		switched; Qmax = 60 l/min; not mechanically limited		S060N
		proportional; Qmax = 60 l/min; mechanically limited		P060L
		proportional; Qmax = 60 l/min; not mechanically limited		P060N
07	Hydraulic system	Open-Center-System		OC
08	Secondary pressure relief	No preset default		999
		Preset default 250 bar		250

Some theoretical configurations might be not feasible for technical reasons. For relating questions please ask for our advice.

5 Description of Characteristics in Accordance with Type Code

5.1 Variant

The flow control valve consists of a 3-way flow control valve (input pressure compensator), a 4/3 directional valve with the consumer connections and a pressure relief valve plate with integrated suction valves.

The directional valve is either operated with an electrical solenoid or a hydraulic piloting switching or proportional.

5.2 Connections

electrical versions

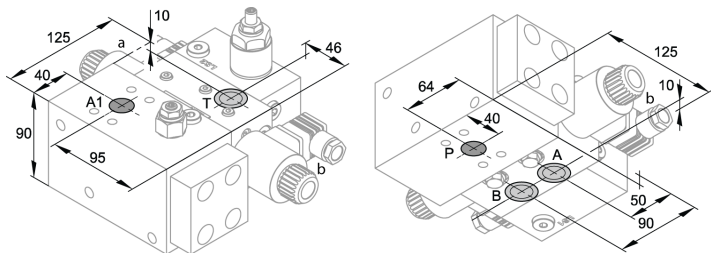

ports	Connection Size	
P, A1	SAE 3/4"	SAE 1"
A, B, T	G 1/2"	

Hydraulic versions

Änderungen vorbehalten

Datenblatt: FC1-1N_E.docx

01.08.2023

4/9

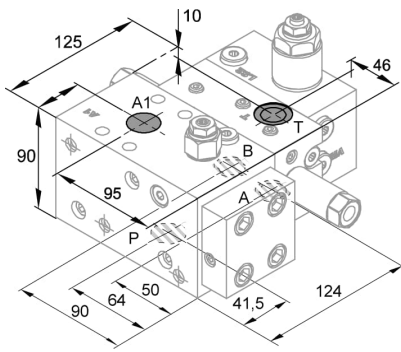

ports	Connection size	
P, A1	SAE 3/4"	SAE 1"
A, B, T	G 1/2"	
VStA, VStB	G 1/4"	

5.3 Input volume flow

Der maximale Eingangsvolumenstrom beträgt 300 l/min bei der SAE 3/4" Version und 400 l/min bei der SAE 1" Version.

Druckverlust in Abhängigkeit vom Eingangsvolumenstrom

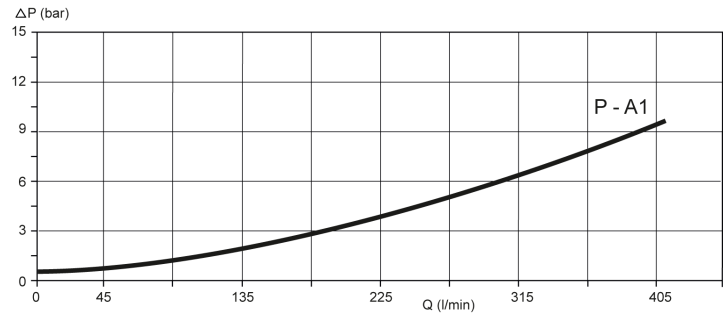

5.4 Maximum permissible pressure

Der maximal zulässige Druck am Eingang (P) des Stromregelventils beträgt 400 bar. Der maximal zulässige Druck an den Ausgängen (A, B) des Stromregelventils beträgt 320 bar

5.5 Actuation

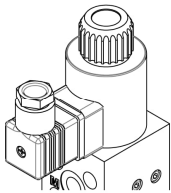

Gerätedose für Anschlussstecker: 12S001 / 24S001 12P001 / 24P001

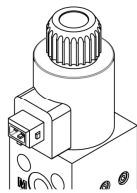

Anschlussstecker Junior Timer

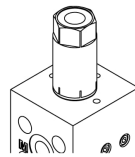

Hydraulische Vorsteuerung, Pmax= 50 bar

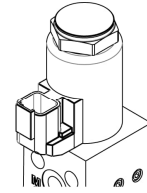

DR-Deutsch DT04-2P

5.6 Hydraulic system

On valves which are designed for open centre systems (Option: OC, 3-way flow controller), output line A1 is open and the LS connections are closed off. In this design, the remainder of the input flow is led on to outlet port A1.

5.7 Output volume flow

The maximum output flow rate is:
 - switching versions 10-60 l/min
 - proportional versions 0-40 l/min

Flow rate characteristic P to A or B (proportional version) measured with pump pressure 200 bar and load pressure of 100 bar

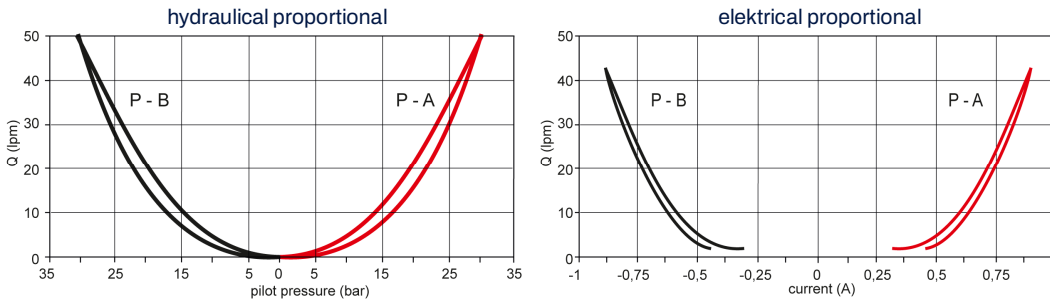

5.8 Secondary pressure limitation

The maximum operating pressure of the attachment is set by default to 250 bar.

6 Installation

6.1 General remarks

- Observe all installation and safety information of the construction machine manufacturer.
- Only technically permitted changes are to be made on the construction machine.
- The user has to ensure that the device is suitable for the respective application.
- Application exclusively for the range of application specified by the manufacturer.
- Before installation or dismantling, the hydraulic system is to be depressurized.
- Settings are to be made by qualified personnel only.
- May only be opened with the approval of the manufacturer, otherwise the warranty is invalidated.

6.2 Connection suggestion

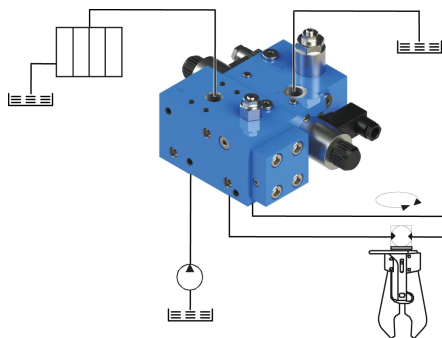

NOTE

This connection recommendation is not guaranteed. The functionality and the technical specifications of the construction machine must be checked. It must be ensured that the construction machine is suitable in terms of technology and safety for the operation of this valve.

6.3 Installation - Space

- Observe the connection labels.
 - Observe the strength category and torsional moment of the clamp bolts.
 - Do not damage seals and flange surface.
 - The air must be exhausted from the hydraulic system.
 - Ensure that the support element is level.
 - Ensure that the valve is not bent during installation.
 - Ensure that there is sufficient free space for setting and installation work.
- Install the flow control valve on the support element using M10 bolts.
 - Make electrical connections.
 - Secure connector with screw (1).



CAUTION! Hydraulic hoses must not come into contact with the flow control valve as they will suffer thermal damage.

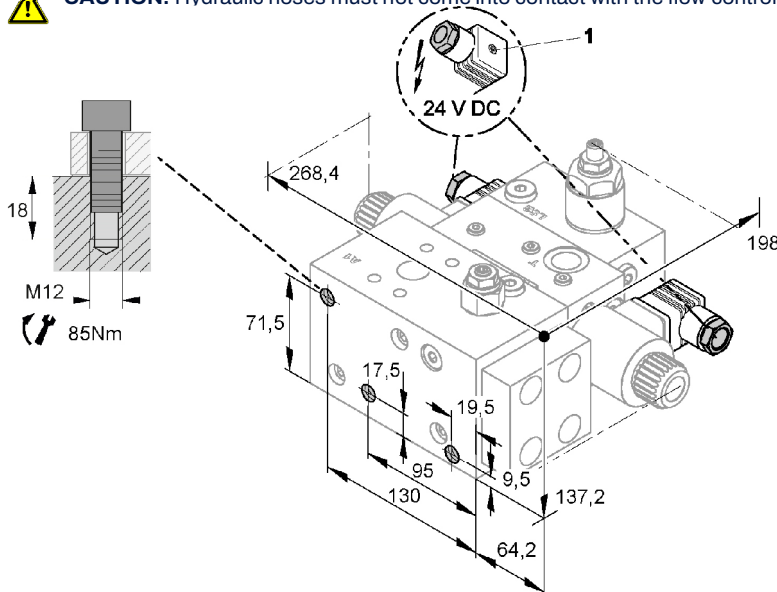

SAE 1" (M12 - 10.9) \curvearrowright 130 Nm

SAE 3/4" (M10 - 10.9) \curvearrowright 70 Nm

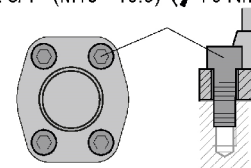

6.4 Setting the output flow rate

For switching versions only; not for proportional versions

- ATTENTION**
During operation, the valve can heat up to the oil temperature.
- CAUTION!**
Do not unscrew the set-screws (1) more than 61 mm out of the housing.
- NOTE**
The counter-nut (3) is to be replaced after being used five times. The priority flow can be set between 10 – 60 l/min. The factory setting is 35 l/min.

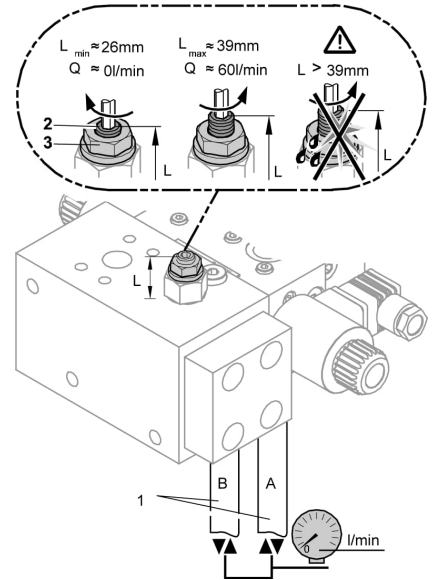

6.5 Setting the pressure relief for the attachment

ATTENTION
During operation, the valve can heat up to the oil temperature.

CAUTION!
Do not unscrew the set-screws (2) more than 61 mm out of the housing.

NOTE
The counter-nut (3) is to be replaced after being used five times. The maximum operating pressure of the attachment can be set between 100 – 320 bar. The factory setting is 200 bar.

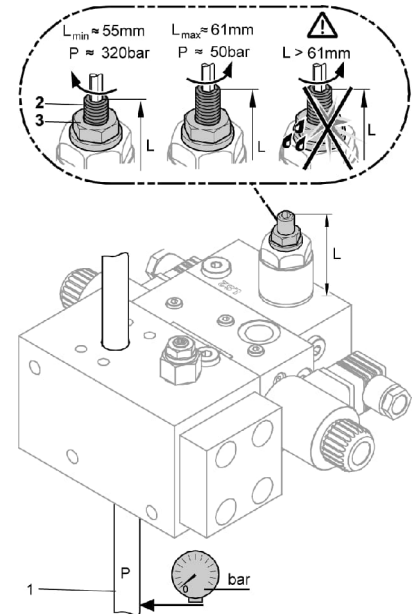

- a. Ensure that the flow control valve is not under pressure
- b. Connect the pressure gauge
- c. Switch on the hydraulics
- d. Undo the counter-nut (3)
- e. Adjust the maximum operating pressure of the attachment:
Increase: Turn the set-screw (2) to the right.
Reduce: Turn the set-screw (2) to the left.
- f. Secure setting with a counter-nut (3)
- g. Switch off the hydraulics
- h. Depressurize the flow control valve
- i. Remove the measurement device
- j. Check tightness

6.6 Dimensions

Electrical version

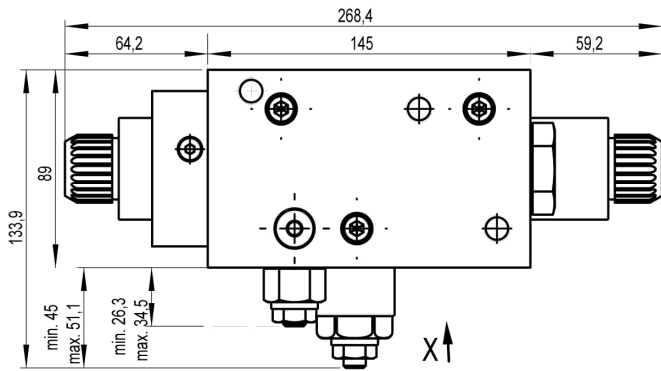

Hydraulic version

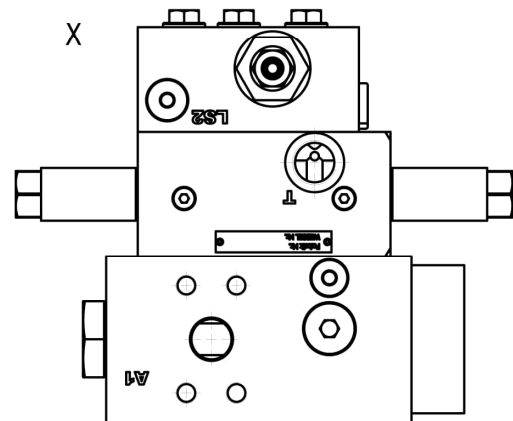
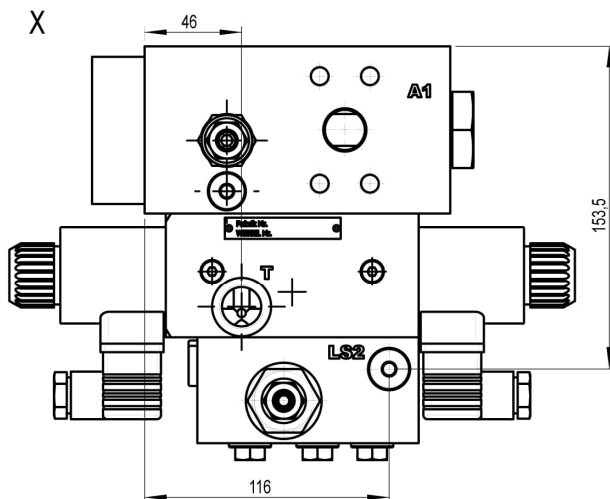
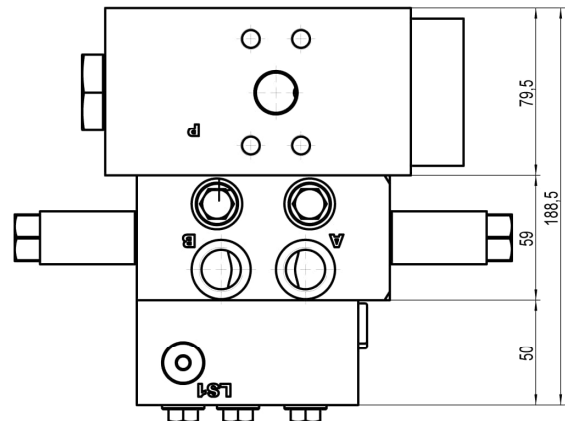
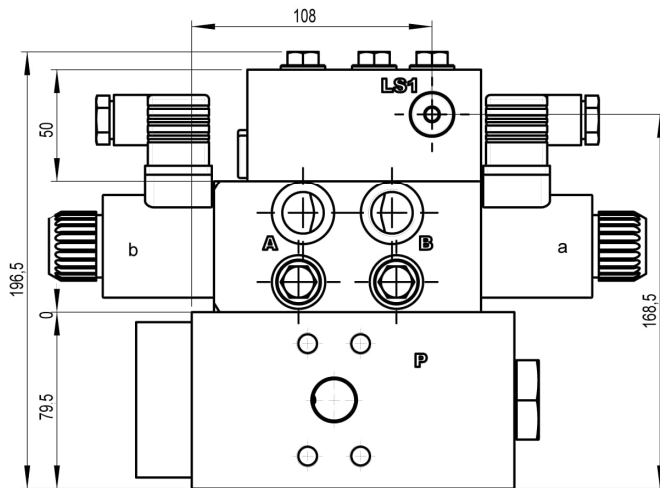
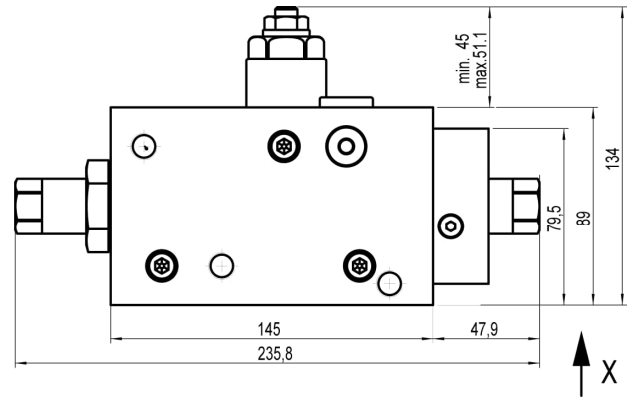

7 Notes, standards and safety requirements

7.1 General remarks

- The views in drawings are shown in accordance with the European normal projection variant
- A comma (,) is used as a decimal point in drawings
- All dimensions are given in mm

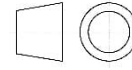

7.2 Standards

The following standards must be observed when installing and operating the valve:

- EN 563, Temperatures on accessible surfaces
- EN 982, Safety requirements for fluid technology systems and their components.

8 Accessories

421.082.406.9 - check valve block double

