

Table of Contents

1	Product Description	2
1.1	Applications.....	2
1.2	Mounting Location (Recommendation)	2
2	Function	2
2.1	Eigenschaften	2
3	Technical Data	3
4	Ordering Information	4
5	Description of Features according to Type Code	5
5.1	Design	5
5.2	Connection Ports	5
5.3	Inlet Volume Flow	5
5.4	Pressure loss in relation to input flow rate.....	5
5.5	Maximum permissible pressure.....	5
5.6	Actuation.....	5
5.7	Output flow rate.....	5
5.8	Hydraulic system	5
5.9	Secondary protection.....	5
6	Installation	6
6.1	General Instructions	6
6.2	Connection Proposal.....	6
6.3	Mounting - Mounting Space.....	6
6.4	Setting the output flow (Only available in the version " mechanically adjustable" SXXL & PXXL, see Type code)	7
6.5	Setting the pressure relief for the attachment.....	7
6.6	Dimensions.....	8
7	Notes, Standards and Safety Instructions	9
7.1	General instructions.....	9
7.2	Standards.....	9
8	Accessories	9

1 Product Description

The flow control valve allows the operation of two-way consumers (rotary motors for shears and grippers, tilting buckets, sweeper brushes) on constructions machines that are not equipped for them.

The attachment can be used simultaneously in conjunction with normal construction machine functions.

1.1 Applications

The flow control valve is used to control functions which only require a low flow rate.

1.2 Mounting Location (Recommendation)

In closed center hydraulic systems (load sensing systems), it is recommended that the flow control valve be installed as a bypass between the pump and the main control system, by means of a T-piece in parallel to the main control valve.

2 Function

The flow control valve divides a partial volume flow from the main pump volume flow in order to operate an additional consumer. When the flow control valve is activated it supplies the additional consumer via ports A and B. A Load-Sensing-Signal is generated in the valve and can control the pump according to the additional need of volume flow.

In the switching and also in some proportional versions the output volume flow can be limited mechanically by means of an adjustable orifice.

The consumer volume flow is switched or proportional controlled electrically or hydraulically by means of a 3-way valve which also controls the direction of the movement of the consumer. A pressure limiting valve protects the consumer against too high pressure even if the flow control valve is not activated. Internal suction valves avoid cavitation in the consumer.

The flow control valve contains two LS-ports. Port LS1 is internally equipped with a check valve in order to minimize the installation effort in hydraulic systems which do not require a shuttle valve.

Port LS2 is not equipped with a check valve. The LS-signal has to be routed into the LS-circuit of the construction machine via a shuttle valve.

The maximum operating pressure for the attachment can be set by the user. The maximum volume flow can be limited mechanically (only optional in valves with proportional control). If the flow control valve is not activated, the entire flow is available for the construction machine's main functions

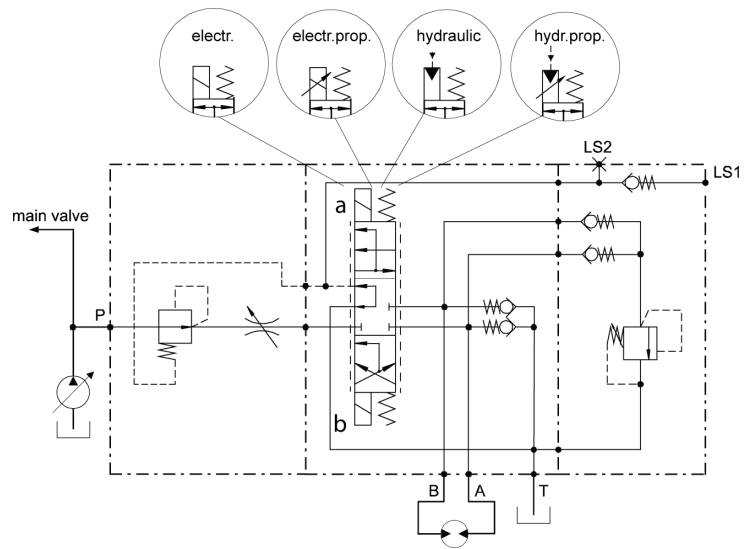

2.1 Eigenschaften

Can be used with all standard closed center hydraulic systems

Pressure protection of consumer ports

Simple expansion of a hydraulic system for attachments with low flow requirements

Electrically or hydraulic switchable or proportional control of the attachment is possible

Integrated suction valves for both attachment ports

3 Technical Data

Criteria	Unit	Value, applicable to all versions
Installation position		Any
Weight	kg	Approx. 9.0
Maximum input pressure (P)	bar	420
Adjustable attachment pressure	bar	50-320, factory setting 200
Plant-preset output flow rate	l/min	35 or proportionally controllable
Output flow rate accuracy	%	± 8
Maximum recommended tank pressure (T)	bar	approx. 5
Maximum input flow (P)	l/min	60 switching, 40 proportional
Hydraulic fluid		Mineral oil (HL, HLP) conforming with DIN 51524, other fluids upon request
Hydraulic fluid pressure range	°C	-20 to +80
Ambient temperature	°C	< +50
Viscosity range	mm ² /s	2.8 - 500
Contamination grade		Filtering conforming with NAS 1638, class 9, with minimum retention rate β ₁₀ ≥75
Electrical proportional operated version		
Supply voltage prop. version	VDC	12 or 24
Control	Hz	Controlled flow with PWM frequency 100 Hz
Resistor R20	Ohm	19.2 (at 24 VDC); 5 (at 12 VDC)
Flow limit I _g :	A	0.8 (at 24 VDC); 1.6 (at 12 VDC)
Solenoid switch duty cycle	%	100
DIN 40050 protection class:		IP 65
Current supply		Device connector / ISO 4400 angle connector or AMP Junior Timer connector or „Deutsch“connector r DT04-2P
Electrical switchable version		
Supply voltage switching version	VDC	12 or 24
Voltage tolerances	%	± 10
Solenoid switch power consumption	W	33
Solenoid switch flow rate consumption	A	2.9 at 12 VDC, 1.4 at 24 VDC
Solenoid switch duty cycle	%	100
DIN 40050 protection class:		IP 65
Electrical connection		Device connector / ISO 4400 angle connector or AMP Junior Timer connector or „Deutsch“connector r DT04-2P

4 Ordering Information

FC2	1L	03D	XXX	420	XXX	XXX	CC	XXX
00	01	02	03	04	05	06	07	08
00	Product group	Flow control valve for dual-acting consumers						FC2
01	Construction type	4/3 Wegeventil für Closed-Center (LS)						1L
02	Connections	4/3-way valve for closed center systems						03D
03	Max. input flow rate G ½"	electr. proportional Version max. 40 l/min						XXX
		switchable operation & hydr.proportionale Version max. 60 l/min						
04	Max. permissible pressure	port P = 420 bar						420
05	Actuation	Electrical switching 12 VDC – ISO 4400 angle plug connection						12S001
		Electrical switching 24 VDC – ISO 4400 angle plug connection						24S001
		Electrical proportional 12 VDC – ISO 4400 angle plug connection						12P001
		Electrical proportional 24 VDC – ISO 4400 angle plug connection						24P001
		Electrical switching 12 VDC – connection via Junior Timer plug						12S002
		Electrical switching 24 VDC – connection via Junior Timer plug						24S002
		Electrical proportional 12 VDC – connection via Junior Timer plug						12P002
		Electrical proportional 24 VDC – connection via Junior Timer plug						24P002
		Electrical switching 12 VDC – connection via „Deutsch“ Stecker DT04-2P						12S003
		Electrical switching 24 VDC – connection via „Deutsch“ Stecker DT04-2P						24S003
		Electrical proportional 12 VDC – connection via „Deutsch“ Stecker DT04-2P						12P003
		Electrical proportional 24 VDC – connection via „Deutsch“ Stecker DT04-2P						24P003
		Hydraulic switching – VST connection G ¼" ISO 1179-1						HYS03B
		Hydraulic proportional – VST connection G ¼" ISO 1179-1						HYP03B
06	Output flow rate	switching; Q _{max} = XXX l/min; mechanically adjustable						SXXXL
		switching; Q _{max} = XXX l/min; mechanically no adjustable						SXXXN
		proportional; Q _{max} = XXX l/min; mechanically adjustable						PXXXL
		proportional; Q _{max} = XXX l/min; mechanically no adjustable						PXXXN
07	Hydraulicsystem	Closed-Center-System						CC
08	Secondary pressure relief	No preset default						000
		Preset default 250 bar						250

Some theoretical configurations might be not feasible for technical reasons. For relating questions please ask for our advice.

5 Description of Features according to Type Code

5.1 Design

The flow control valve consists of an input valve for the inlet volume flow, a switchable or proportional directional valve including the outlet connections and a pressure relief valve assembly with integrated suction valves.

The directional valve is operated switchable or proportional either by means of an electrical magnet or a hydraulic piloting port. This design is used in Closed-Center-Hydraulicsystems and is connected with its P-port via a T-piece directly to the pump. The pump volume flow is controlled by the LS-signal.

5.2 Connection Ports

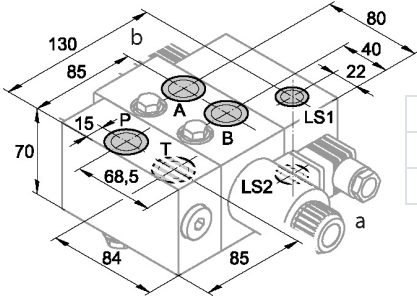

Connnection	Connnection sizes
P, T, A, B	G ½ ISO 1179-1
LS1, LS2	G ¼ ISO 1179-1

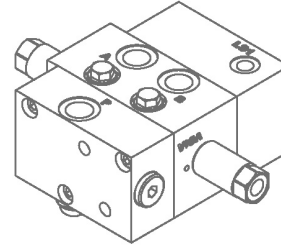

Connnection	Connnection sizes
P, T, A, B	G ½ ISO 1179-1
LS1, LS2, VStA, VStB	G ¼ ISO 1179-1

5.3 Inlet Volume Flow

The input flow rate corresponds with the outlet volume flow and is limited to 60 l/min for the switchable valve version and 40 l/min for the proportional valve version.

5.4 Pressure loss in relation to input flow rate

Proportional Version : Characteristic A or B to tank

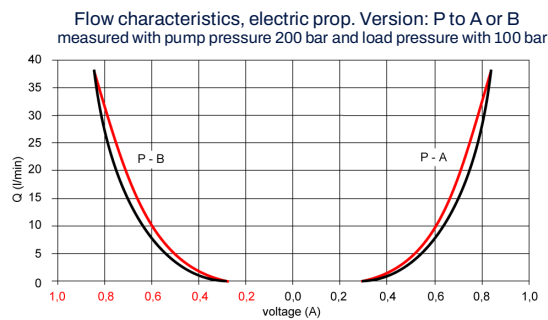
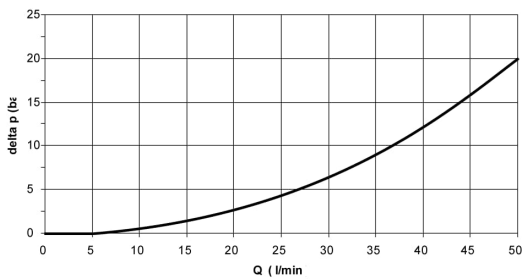

5.5 Maximum permissible pressure

The maximum permissible input (P) pressure of the flow control valve is 400 bar. The attachment connections can be loaded up to 320 bar.

5.6 Actuation

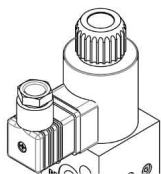

appliance socket for connecting plug:
12S001 / 24S001

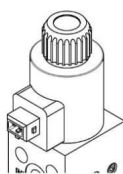

connecting plug Junior Timer

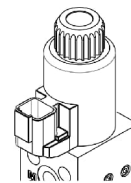

„Deutsch“ plug DT04-2PIN

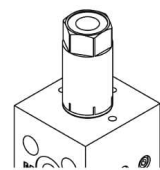

Hydraulical pilot control

5.7 Output flow rate

The output flow rate is identical to the input flow rate. In proportional versions, the output flow rate is controlled by the electrical or hydraulic piloting signal.

5.8 Hydraulic system

CC hydraulic system

This design is used in Closed-Center-Hydraulicsystems and is connected with its P-port via a T-piece directly to the pump. The LS signal connections, LS1 or LS2, are dependent on the construction machine's hydraulic.

Valve for open-center systems see: Data sheet FC2-1N

5.9 Secondary protection

The pressure relief valve for attachment connections A and B is preset to 250 bar by default.

6 Installation

6.1 General Instructions

Observe all installation and safety information of the construction machine manufacturer.
 Only technically permitted changes are to be made on the construction machine.
 The user has to ensure that the device is suitable for the respective application.
 Application exclusively for the range of application specified by the manufacturer.
 Before installation or dismantling, the hydraulic system is to be depressurized.
 Settings are to be made by qualified personnel only.
 May only be opened with the approval of the manufacturer, otherwise the warranty is invalidated.

6.2 Connection Proposal



NOTE

This connection recommendation is not guaranteed. The functionality and the technical specifications of the construction machine must be checked. It must be ensured that the construction machine is suitable in terms of technology and safety for the operation of

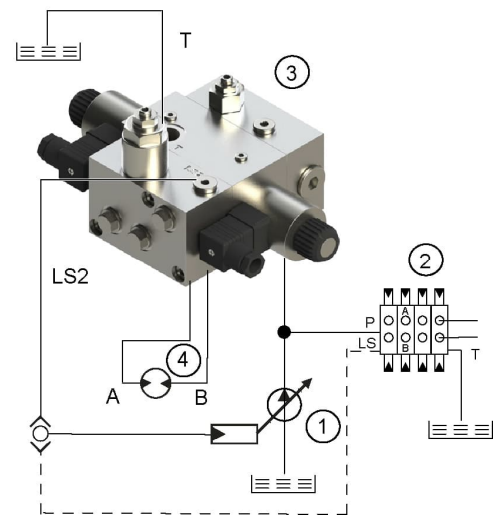
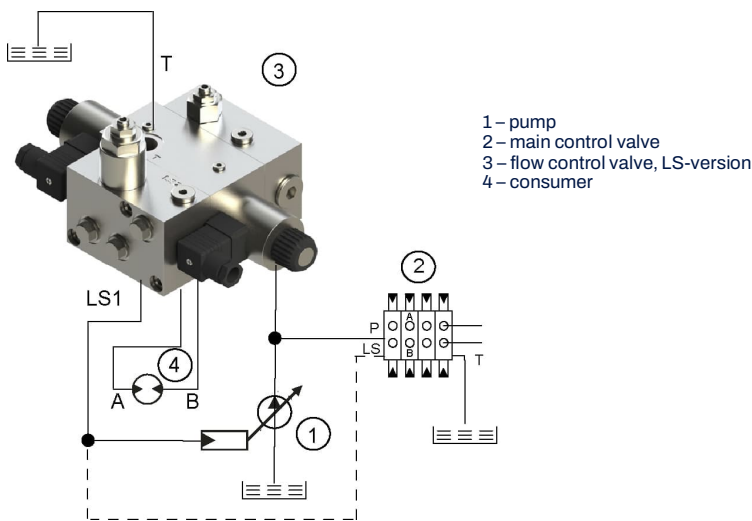

6.3 Mounting - Mounting Space

Observe the connection labels.
 Observe the strength category and torsional moment of the clamp bolts.
 Do not damage seals and flange surface.
 The air must be exhausted from the hydraulic system.
 Ensure that the support element is level.
 Ensure that the valve is not bent during installation.
 Ensure that there is sufficient free space for setting and installation work.

- Install the flow control valve on the support element using M12 bolts.
- Make electrical connections.
- Secure connector with screw (1).



CAUTION!

Hydraulic hoses must not come into contact with the flow control valve as they will suffer thermal damage.

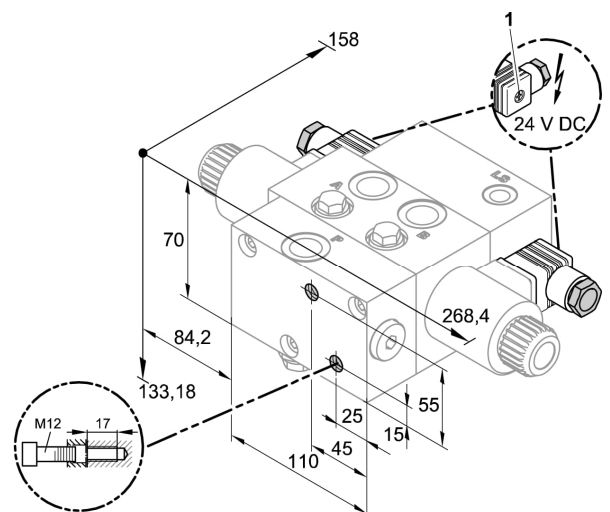

Installation space is applicable to both electrical and hydraulic versions.

6.4 Setting the output flow (Only available in the version "mechanically adjustable" SXXL & PXXL, see Type code)

 Do not unscrew the set-screws (2) more than 39 mm out of the housing.

 **NOTE**
The counter-nut (1) is to be replaced after being used five times.
The volume flow limitation can be set between 0 – 60 (40) l/min. The factory setting is 35 l/min.

- Make sure that the flow control valve is depressurized
- Undo the counter-nut (1)
- Adjust the priority flow...
 - ...**Increase**: Turn the set-screw (2) to the left
 - ...**Decrease**: Turn the set-screw (2) to the right
- Tighten the counter-nut (1)

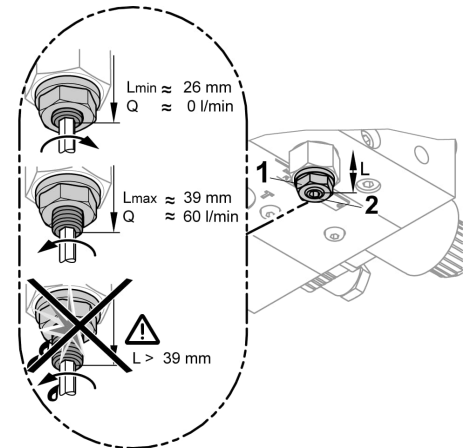

6.5 Setting the pressure relief for the attachment

ATTENTION

During operation, the valve can heat up to the oil temperature.

 **CAUTION!**
Do not unscrew the set-screws (2) more than 61 mm out of the housing.
Do not make any settings while the flow control valve is under pressure.

NOTE

 The counter-nut (1) is to be replaced after being used five times.
The maximum operating pressure of the attachment can be set between 50 – 320 bar. The factory setting is 200 bar.

- Make sure that the flow control valve is depressurized
- Undo the counter-nut (1)
- Adjust the maximum operating pressure of the attachment...
 - ... **Increase**: Turn the set-screw (2) to the right
 - ... **Decrease**: Turn the set-screw (2) to the left
- Secure settings with a counter-nut (1)**

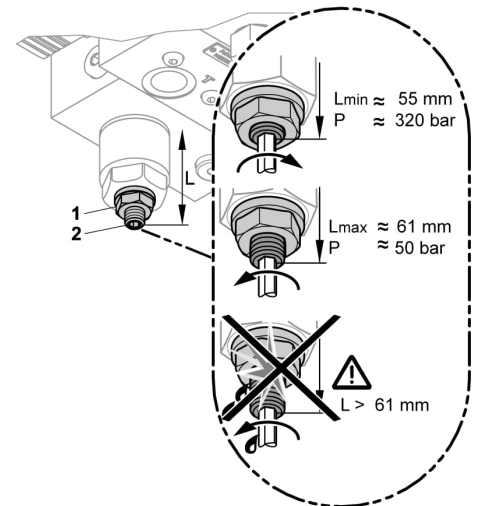

6.6 Dimensions

electrical version

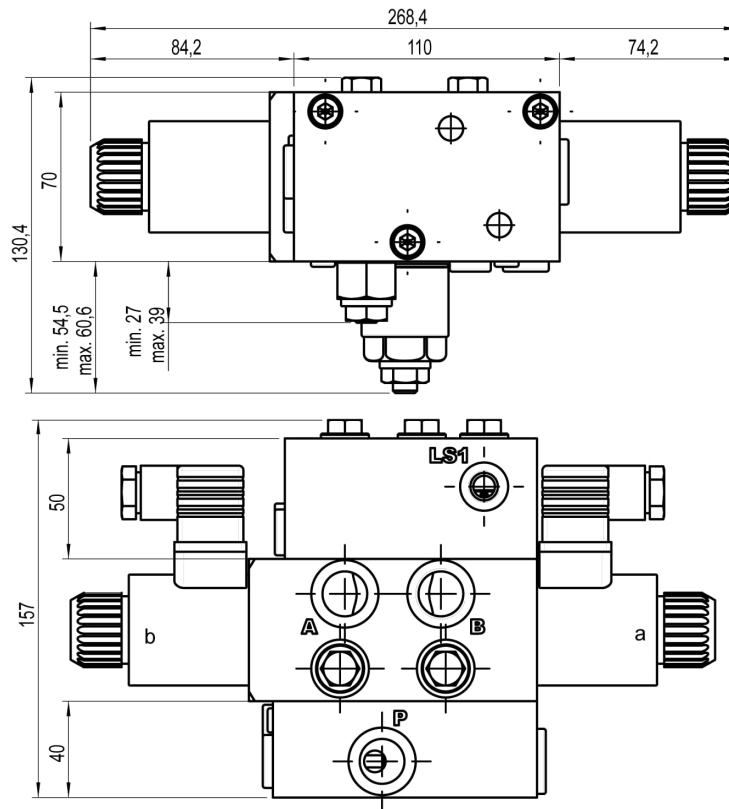

hydraulic version

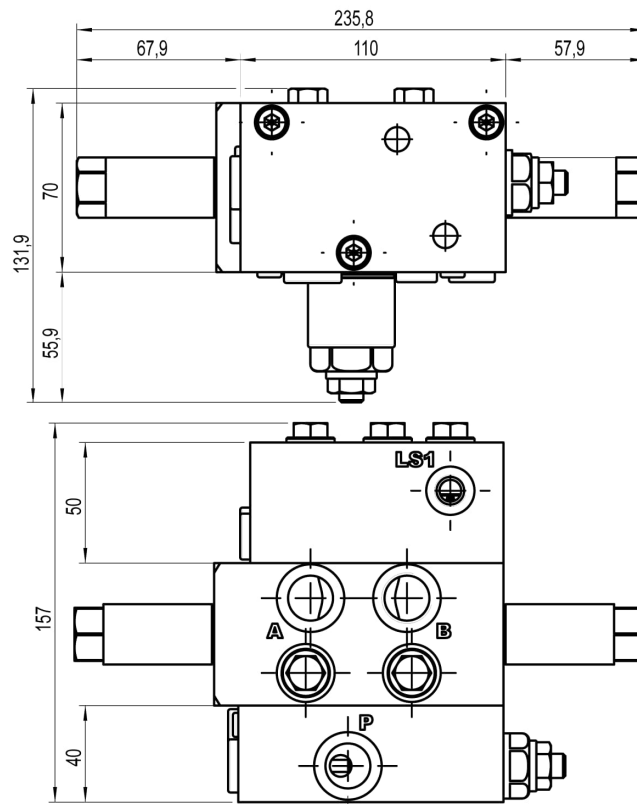

7 Notes, Standards and Safety Instructions

7.1 General instructions

- The views in drawings are shown in accordance with the European normal projection variant

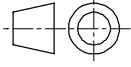

- A comma (,) is used as a decimal point in drawings
- All dimensions are given in mm

7.2 Standards

The following standards are to be observed because of the surface temperatures on the load control valve:

- EN 563, Temperatures on surfaces that can be touched.
- EN 982, Safety-technical requirements for fluid-technical systems and their components.

8 Accessories

- Junior-Timer plug-in connector: Part number: 340.305.900.6