



## Table of Contents

<b>1</b>	<b>Product Description</b> .....	<b>2</b>
1.1	Application.....	2
1.2	Mounting location.....	2
1.3	Characteristics.....	2
1.4	Function.....	2
1.5	Adjustment options.....	2
<b>2</b>	<b>Technical Data</b> .....	<b>3</b>
<b>3</b>	<b>Ordering Information</b> .....	<b>4</b>
<b>4</b>	<b>Description of Characteristics in Accordance with Type Code</b> .....	<b>5</b>
4.1	Characteristic 2: Connections.....	5
4.2	Characteristic 2: Connections.....	5
4.3	Characteristic 3: Spool.....	5
4.4	Characteristic 4: Pressure setting.....	5
4.5	Characteristic 5: Actuation.....	5
4.6	Characteristic 6: Opening pressure.....	5
4.7	Characteristic 7: Setting compensation.....	5
4.8	Characteristic 8: Lowering speed adjustable.....	5
<b>5</b>	<b>Installation</b> .....	<b>6</b>
5.1	General remarks.....	6
5.2	Connection recommendations.....	6
5.3	Installation - space.....	6
5.4	Setting „opening pressure“.....	6
5.5	Setting Pressure limitation.....	7
<b>6</b>	<b>Dimensions</b> .....	<b>7</b>
<b>7</b>	<b>Notes, Standards and Safety Requirements</b> .....	<b>8</b>
7.1	General remarks.....	8
7.2	Standards.....	8
7.3	Safety requirements.....	8
<b>8</b>	<b>Accessories</b> .....	<b>8</b>

## 1 Product Description

In case of a pipe or tube rupture load control valves avoid uncontrolled movement of the cylinder. In some countries these valves are required by law when a construction machine is used for load lifting purposes. They also serve for an exact and stable positioning of the boom and enable sensitive and even movement processes. Load control valves can compensate for leakages on the main control valves in older construction machines. WESSEL load control valves stand for an excellent sensitivity and a very direct response to the handle's stroke. In any case they are leakage free.

The pipe rupture valve in the variant 3P can be used for the most standard applications.

### 1.1 Application

Lifting, arm and bucket cylinders in backhoes, lifting gear in wheel loaders

### 1.2 Mounting location

The pipe rupture valve is installed in the line to be protected between the control valve and the hydraulic cylinder as close as possible to the cylinder.

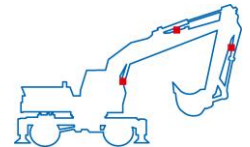

### 1.3 Characteristics

- Meets the requirements of standards: DIN24093, ISO 8643, EN 474 under certain conditions. See Chapter 6.2
- Start opening independent of the load pressure
- Sensitive control with low hysteresis
- Leakage-free
- Hose rupture valve piston pressure-compensated
- Compact construction
- Pipeline installation
- Surge line for parallel operation for the minimization of the cylinder pressure differences
- Pressuring limiting valve with upstream filter sieve for protecting the cylinder

### 1.4 Function

The pipe rupture valve is closed and leakage free in the idle position (Z → ST). The cylinder cannot lower.

When deploying the cylinder (ST → Z), the hydraulic fluid is fed to the cylinder via a check valve.

Pilot control pressure in the VSt connection uses control surfaces to open the pipe rupture valve piston against a pressure spring and introduces a jolt-free lowering movement. As the pilot control pressure continues to increase, the entire control cross-section of the hose rupture valve piston is released and the maximum lowering speed is reached. If a hose or pipe breaks, the pipe rupture valve controls the maximum lowering speed to the setting defined with the control lever and the maximum specified lowering speed is thereby not exceeded. By moving the control lever into its neutral position further lowering is prevented. The hose rupture valve piston is load-compensated so that no closing force from the return pressure affects the pipe rupture valve piston.

The secondary valve is connected with connection Z and opens up to connection VSt when the permanently defined maximum pressure is achieved, which opens the hose rupture valve piston and allows pressure to be decreased from Z to St. A downstream pressure restriction valve is required if the main directional control valve has a closed central position (A).

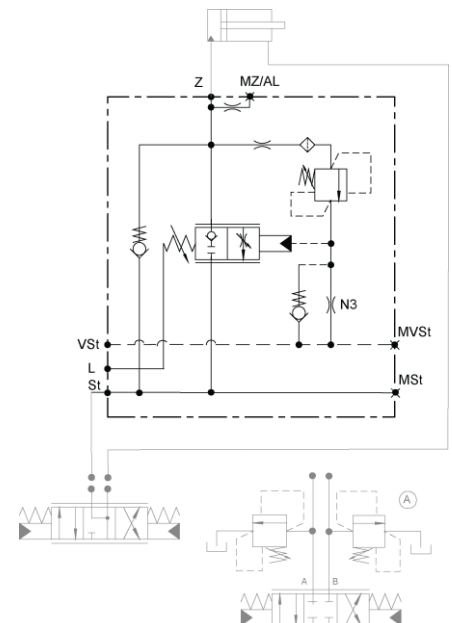

### 1.5 Adjustment options

- Opening Start of the Load Control Valve
- Opening Start of the Pressure Limiting Valve Adjustable

## 2 Technical Data

Criterion		Units	Value
Z, St			G 3/4"
Max. operating pressure		bar	420
Range pressure setting		bar	250 – 420
Pressure setting			See type code feature 04: Pressure setting
Max. volume flow			See type code feature 03: Control slider
Weight		kg	10.0
Setting control pressure		bar	6 – 10
Full opening		bar	Opening pressure + leak oil pressure + 17
Connection	Connection size		Connection
Z, St	G ¾" (ISO 1179-1)	bar	Z, St
VSt	G ¾" (ISO 1179-1)	bar	VSt
L	G ¾" (ISO 1179-1)	bar	L
AL/MZ, MSt, MVSt	M8x1	bar	AL/MZ, MSt, MVSt
Installation position			Any
Criterion	Units	Value	
Hydraulic fluid		Mineral oil (HL, HLP) conforming with DIN 51524, other fluids upon request	
Hydraulic fluid temperature range	°C	-20 – +80	
Ambient temperature:	°C	< +50	
Viscosity range	mm <sup>2</sup> /s	2.8 – 500	
Contamination grade		Filtering conforming with NAS 1638, class 9, with minimum retention rate $\beta_{10} \geq 75$	

### 3 Ordering Information

<b>LHB</b> 00	<b>3P</b> 01	<b>03E</b> 02			<b>HYP 03B</b> 05		<b>00</b> 07		
00	Product group	Load Control Valve Boom							<b>LHB</b>
01	Variant	Pipeline installation							<b>3P</b>
02	Connections	Cylinder (control valve)	G 3/4"						<b>03E</b>
03	Spool	Design of the spool optimized for the specified volume flow; [l/min]							<b>100</b> <b>150</b>
04	Pressure setting	Pressure limiting valve opens at a volume flow of 10 l/min and a load pressure (Z) as of...	200 bar to 420 bar, Standard 420 bar						<b>XXX</b>
05	Actuation	Hydraulically proportional, connection G1/4							<b>HYP 03B</b>
06	Opening point pusher	Hose rupture valve opens at a pilot control pressure as of...	6 bar to 10 bar, Standard 8 bar						<b>XXX</b>
07	Setting compensation	No compensation							<b>00</b>
08	Lowering speed adjustable						No		<b>0</b>

XXX – permanently predetermined characteristics   
 XXX – characteristics selectable by customer   
 ■ available   
 ○ not available  
 Different configurations are unfortunately not implementable for technical reasons. Please let us know if you have questions

## 4 Description of Characteristics in Accordance with Type Code

### 4.1 Characteristic 2: Connections

Line installation

### 4.2 Characteristic 2: Connections

The valve is installed in the supply line near the cylinder to be protected (connection Z). The supply line from the control valve takes place via the connection ST.

### 4.3 Characteristic 3: Spool

The control slider is calculated to the maximum desired volume flow (Z → ST). Criterion: Nominal volume flow, in which a maximum pressure loss ( $\Delta p$ ) of 50 bar is generated (Z → ST)

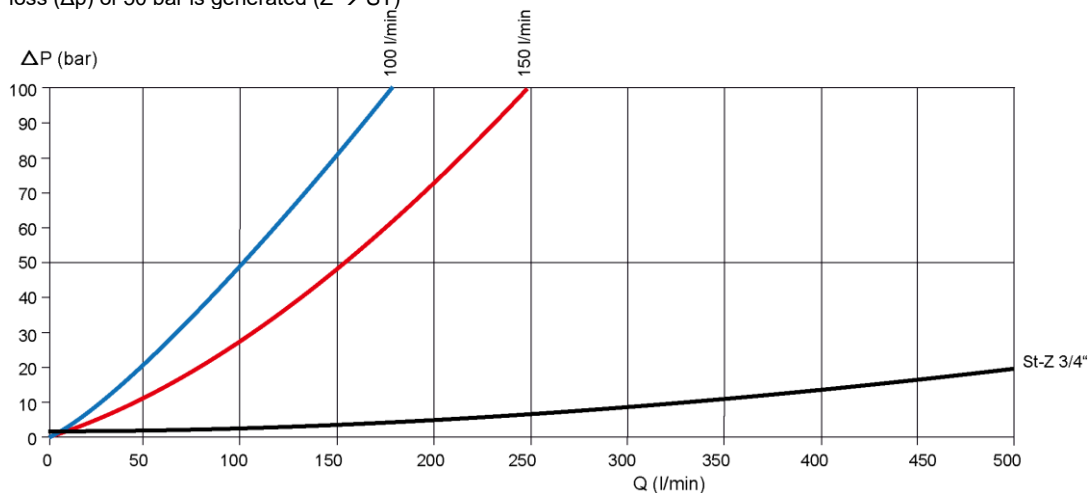

### 4.4 Characteristic 4: Pressure setting

Setting of the pressure restriction valve for securing the cylinder (connection Z)

### 4.5 Characteristic 5: Actuation

Actuation type of the valve. As a rule, this is "hydraulically proportional" and connection size of the pilot control connection.

### 4.6 Characteristic 6: Opening pressure

Level of the pilot control pressure (connection VST), in which the valve opens and the cylinder begins its lowering movement.

### 4.7 Characteristic 7: Setting compensation

**Compensation** of the impact of load pressure on the lowering speed. The setting is performed in the factory and cannot be changed.

**No compensation:**

The load pressure had no impact on the opening cross-section of the hose rupture valve.

Higher load pressure – higher lowering speed

### 4.8 Characteristic 8: Lowering speed adjustable

Not available for this variant.

## 5 Installation

### 5.1 General remarks

- Observe all installation and safety information of the construction machine manufacturer.
- Only technically permitted changes are to be made on the construction machine.
- The user has to ensure that the device is suitable for the respective application.
- Application exclusively for the range of application specified by the manufacturer.
- Before installation or dismantling, the hydraulic system is to be depressurized.
- Settings are to be made by qualified personnel only.
- May only be opened with the approval of the manufacturer, otherwise the warranty is invalidated.
- The included connection recommendations are not guaranteed. The functionality and the technical specifications of the construction machine must be checked.

### 5.2 Connection recommendations

**CAUTION!** Hydraulic hoses are not to come into contact with the hose rupture valve because otherwise they are subject to thermal damaging.  
Ensure that standards EN 563 and EN 982 are observed.



- 1 Pump
- 2 Main control device
- 3 Pilot control unit
- 4 Hose rupture valve
- 5 Cylinder

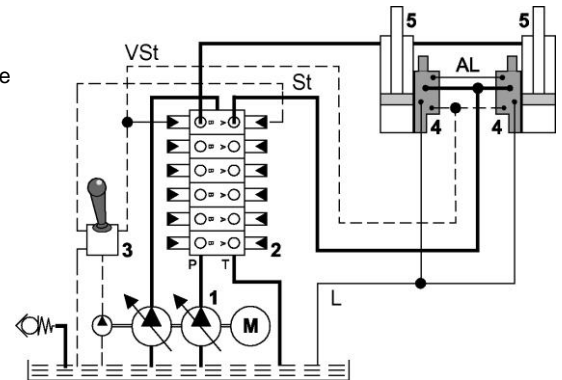

### 5.3 Installation - space

- Observe the connection labels
- Observe the strength category and torsional torque of the clamp bolts
- Do not damage seals and flange surface
- The air must be exhausted from the hydraulic system
- Observe the recommended installation screws

Thread (A)	Strength class	Tightening torque (Nm)	C (mm)
M8x1.25	10.9	32	60

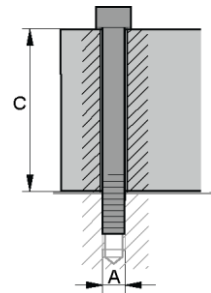

### 5.4 Setting „opening pressure“

The opening start of the hose rupture valve is set in the factory according to type code. A setting during startup is not necessary and, for safety purposes, may only be performed by trained technicians using suitable measuring means.

The setting of the opening start, that is the level of the pilot control pressure, from which the hose rupture valve opens to lower the cylinder, is set on the torque control spring.



#### ATTENTION

During operation, the valve can heat up to the oil temperature.

- Loosen the (1) AF2 safety pin.
- The opening start of the hose rupture valve must be approximately 0.5 bar above the opening start of the main control unit spool.
- The opening point is preset to 8 bar.
- Increase: Turn the set-screw AF6 (2) clockwise.
- Decrease: Turn the set-screws AF6 (2) counter-clockwise.
- 1mm adjustment = 2.9 bar.
- Tighten the safety pin (1) AF2 (3Nm).
- An adjustment of 1mm thread corresponds a variation of the opening pressure fo 2,9 bar.
- Tighten the counernut AF10 (1).

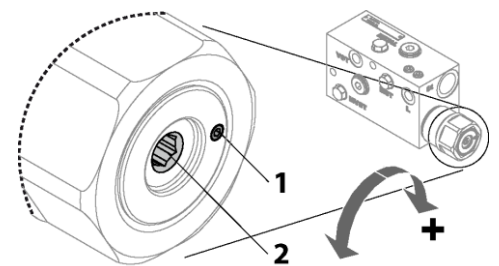

### 5.5 Setting Pressure limitation

The pressure limitation of the load control valve is set in the factory according to type code. A setting during startup is not necessary and, for safety purposes, may only be performed by trained technicians using suitable measuring equipment.

The maximum operating pressure of the pressure valve depends on the maximum operating pressure of the machine. Observe the technical data. The pressure valve is in one of the indicated positions.

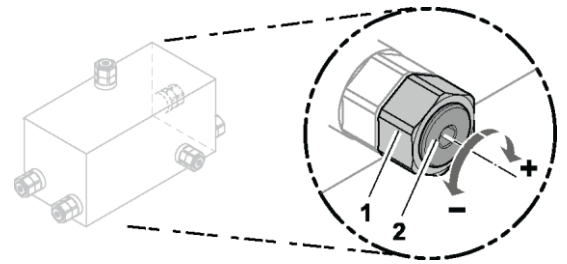

**ATTENTION**

During operation, the valve can heat up to the oil temperature.

- Undo the counternut AF19 (1).
- The operating pressure is set up (see table).
- Increase: Turn the set-screw AF5 (2) clockwise.
- Decrease: Turn the set-screws AF5 (2) counter-clockwise.
- 1 revolution corresponds with 84 bar
- Settings over 420 bar (DIN ISO 6162-2, SAE J518/2 (CODE62)) are not permissible
- Tighten the counternut AF19 (1).

## 6 Dimensions

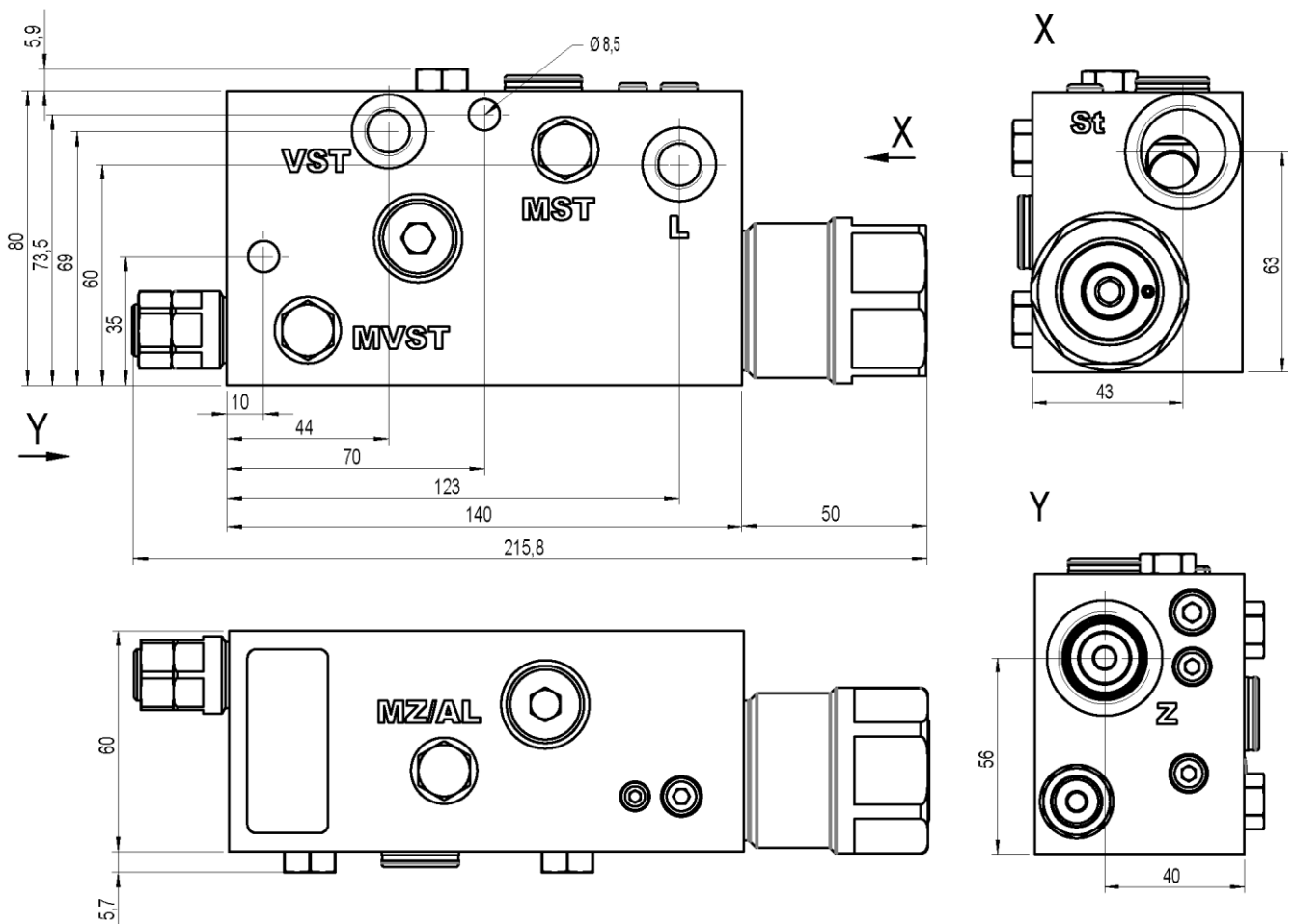

## 7 Notes, Standards and Safety Requirements

### 7.1 General remarks

- The views in drawings are shown in accordance with the European normal projection variant
- A comma ( , ) is used as a decimal point in drawings
- All dimensions are given in mm

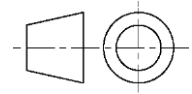

### 7.2 Standards

The load control valve complies with standards:

- DIN 24093
- ISO 8643
- EN 474

The following standards are to be observed because of the surface temperatures on the load control valve:

- EN 563, Temperatures on surfaces that can be touched.
- EN 982, Safety-technical requirements for fluid-technical systems and their components.

### 7.3 Safety requirements

- WESSEL-HYDRAULIK GmbH guarantees utilization of standard and proven safety principles in accordance with ISO 13849-2: 2003, Tables C.1 and C.2 for the construction of the valve described here.
- WESSEL-HYDRAULIK GmbH has a certified quality management system in accordance with DIN EN ISO 9001.
- The MTTFd value can be adopted from machine manufacturers with 150 years of experience for the described valve!
- Note: The user is therefore responsible for complying with the fundamental and proven safety principles according to ISO 13849-2: 2003, Tables C.1 and C.2 for the implementation and operation of the hydraulic component!

## 8 Accessories