

Table of Contents

1	Product Description	2
1.1	Application	2
1.2	Mounting (location)	2
2	Function	2
2.1	Eigenschaften	2
2.2	Einstellmöglichkeiten	2
3	Technical Data	3
4	Technical Data	3
5	Description of Characteristics in Accordance with Type Code	4
5.1	Variant	4
5.2	Connections	4
5.3	Spool	4
5.4	Pressure Setting	4
5.5	Actuation	4
5.6	Opening pressure	4
5.7	Setting Compensation	4
5.8	Lowering speed adjustable	4
6	Installation	4
6.1	General remarks	4
6.2	Connection recommendations	4
6.3	Installation - space	5
6.4	Setting „opening pressure“	5
6.5	Setting Pressure limitation	5
6.6	Setting Maximum lowering speed	5
6.7	Dimensions	6
7	Notes, Standards and Safety Requirements	7
7.1	General remarks	7
7.2	Standards	7
7.3	Safety requirements	7
8	Accessories	7

1 Product Description

In case of a pipe or tube rupture load control valves avoid uncontrolled movement of the cylinder. In some countries these valves are required by law when a construction machine is used for load lifting purposes. They also serve for an exact and stable positioning of the boom and enable sensitive and even movement processes. Load control valves can compensate for leakages on the main control valves in older construction machines. WESSEL load control valves stand for an excellent sensitivity and a very direct response to the handle's stroke. In any case they are leakage free.

The load control valve of variant LHB-3R performs an internal regeneration circuit. The returning volume flow is dammed up by an internal check valve and routed to the rod side of the cylinder when needed (port K). With that the lifting cylinder can be retracted without additional pump volume flow.

1.1 Application

Applications: Boom- stick- and bucket cylinders in excavators

1.2 Mounting (location)

The load control valve is installed in the line to be protected between the main control valve and the hydraulic cylinder and is flanged directly on the cylinder. Additional pipework and piping between load control valve and cylinder is not permissible.

2 Function

The load control valve is closed and leakage free in the idle position (Z \leftrightarrow ST). The cylinder cannot lower.

When deploying the cylinder (ST \leftrightarrow Z), the hydraulic fluid is fed to the cylinder via a check valve (2). Pilot control pressure in the VSt connection uses control surfaces to open the load control valve piston (1) against a pressure spring and introduces a jolt-free lowering movement. As the pilot control pressure continues to increase, the entire control cross-section of the load control valve piston is released and the maximum lowering speed is reached. In the event of a pipe or tube rupture, the load control valve regulates the maximum lowering speed to the setting specified by the control lever. The maximum prescribed lowering speed is thereby not exceeded. By moving the control lever into its neutral position further lowering is stop-ped. The load control valve piston is load-compensated so that no closing force from the return pressure affects the load control valve piston.

The pressure limiting valve (3) is connected with connection Z and opens up to connection VSt when the permanently defined maximum pressure is achieved, which opens the load control valve piston and allows pressure to be released from Z to St.

The regeneration enables a return (via check valve 4) of a partial oil quantity of the bottom side into the rod side (K) of the cylinder depending on the area ratio of the cylinder, the load and the design of the main control unit during the lowering process. Considerably less volume flow is thereby needed by the pump during the lowering of the boom. Depending on the hydraulic system, the saved volume flow can be used for other functions. In any case, the load control valves must be matched for the initial application on the construction machine.

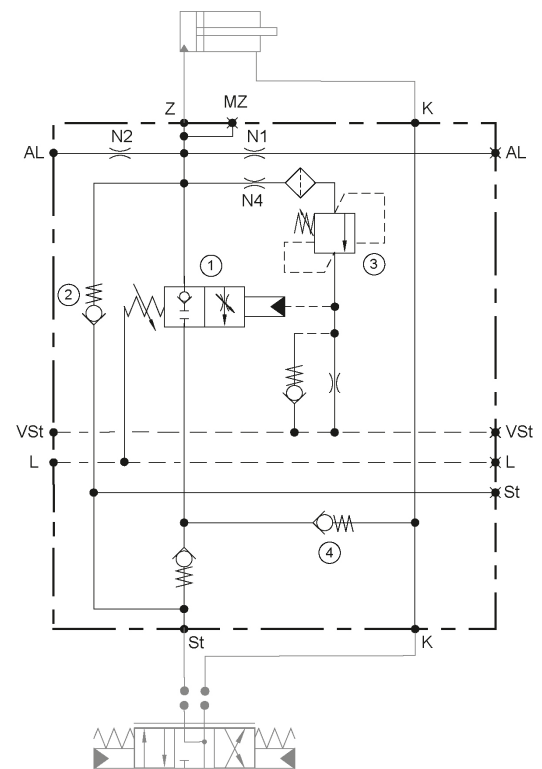

2.1 Eigenschaften

- Meets the requirements of standards: DIN24093, ISO 8643, EN 474
- Start opening independent of the load pressure
- Sensitive control with low hysteresis
- Leakage-free
- Load control valve piston pressure-compensated
- Symmetrical connections to/from the control valve on the right and the left side of the load control valve
- Can be flanged directly onto the cylinder connection
- Surge line for parallel operation for the minimization of the cylinder pressure differences
- Pressuring limiting valve with upstream filter sieve for protecting the cylinder

2.2 Einstellmöglichkeiten

- Opening Start of the Load Control Valve
- Opening Start of the Pressure Limiting Valve Adjustable
- Lowering Speed Limiting Adjustable (optional)

3 Technical Data

Criterion		Unit	Value		
ST, K, Z			SAE 3/4"	SAE 1"	SAE 1 1/4"
			DIN ISO 6162-2, SAE J518 (CODE62)		
Max. operating pressure		bar	420		
Pressure setting range			See type code feature 04: Pressure setting		
Max. volume flow			See type code feature 03: Spool		
weight		Kg	10	16	16,5
Setting of opening start		bar	6 – 10		
Full opening		bar	Opening pressure + leak oil pressure + 17		
	Connection	Connection sizes		Pmax	
VSt	Pilot port	G 3/4; ISO 1179-1	bar	50	
Al	Compensation port	G 3/4; ISO 1179-1	bar	420	
L	Leakage port	G 3/4; ISO 1179-1	bar	3,0	
MSt	measurement port	M8x1, ISO 6149-1	bar	350	
Installation position			any		
Hydraulic fluid			Mineral oil (HL, HLP) conforming with DIN 51524, other fluids upon request		
Hydraulic fluid temperature range		°C	-20 – +80		
Ambient temperature:		°C	< +50		
Viscosity range		mm2/s	2.8 – 500		
Contamination grade			Filtering conforming with NAS 1638, class 9, with minimum retention rate β10≥75		

4 Technical Data

LHB	3R				HYP03B		00	
00	01	02	03	04	05	06	07	08
00	Product group	Load Control Valve Boom						LHB
01	Variant	Compact variant						4K
02	Connections	Cylinder (Main control valve)	SAE 3/4" (DIN ISO 6162-2, SAE J518 (CODE62)) SAE 1" (DIN ISO 6162-2, SAE J518 (CODE62)) SAE 1 1/4" (DIN ISO 6162-2, SAE J518 (CODE62))			Connections		
03	Spool	Design of the spool optimized for the specified volume flow; [l/min]			Versionen SAE 3/4" Versionen SAE 3/4" und 1" Versionen SAE 3/4", 1" und 1 1/4" nur Version SAE 1" und 1 1/4" nur Version SAE 1 1/4"		150 200 250 300 350 400 450 300 500 550 600	
04	Pressure setting	Pressure limiting valve: value refers to a volume flow of 10 l/min	200 bar bis 420 bar, Standard 420 bar			XXX		
05	Actuation	hydraulic proportional, port G1/4						HYP03B
06	Opening pressure	opens at a pilot control pressure as 6 bar to 10 bar, standard 6 bar = 006						XXX
07	Setting compensation	No compensation						00
08	Maximum lowering speed adjustable	No						0
		Yes						1

Different configurations are unfortunately not implementable for technical reasons. Please let us know if you have questions

5 Description of Characteristics in Accordance with Type Code

5.1 Variant

Power saving through regeneration, returning oil is fed to the rod side as needed.

5.2 Connections

The valves are flanged directly on the cylinder to be protected (connection Z). The supply line from the control valve takes place via the connection ST. As a rule, both connections are designed the same (SAE size).

5.3 Spool

The control slider is calculated to the maximum desired volume flow (Z → ST). Criterion: Nominal volume flow, in which a pressure loss (Δp) of maximum 50 bar is generated (Z → ST)

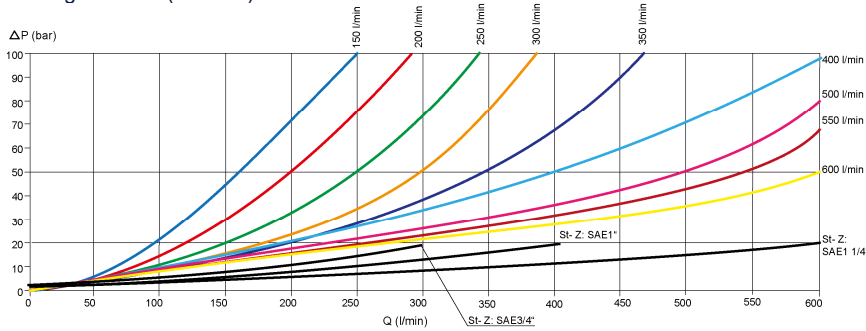

5.4 Pressure Setting

Setting of the pressure restriction valve for securing the cylinder (connection Z). The operating pressure at the ST inlet and at the Z outlet of the valve must not exceed 420 bar for all versions.

5.5 Actuation

Actuation type of the valve. As a rule, this is "hydraulically proportional" connection size of the pilot control connection.

5.6 Opening pressure

Level of the pilot control pressure (connection VSt), in which the valve pusher opens and the cylinder begins its lowering movement.

5.7 Setting Compensation

Compensation of the impact of load pressure on the lowering speed. The setting is performed in the factory and cannot be changed.

No compensation: The load pressure had no impact on the opening cross-section of the hose rupture valve. Higher load pressure – higher lowering speed

5.8 Lowering speed adjustable

In addition to the design of the control spool for a maximum volume control, the lowering speed can be further limited by this setting.

6 Installation

6.1 General remarks

- Observe all installation and safety information of the construction machine manufacturer.
- Only technically permitted changes are to be made on the construction machine.
- The user has to ensure that the device is suitable for the respective application.
- Application exclusively for the range of application specified by the manufacturer.
- Before installation or dismantling, the hydraulic system is to be depressurized.
- Settings are to be made by qualified personnel only.
- May only be opened with the approval of the manufacturer, otherwise the warranty is invalidated.
- The included connection recommendations are not guaranteed. The functionality and the technical specifications of the construction machine must be checked.

6.2 Connection recommendations

CAUTION! Hydraulic hoses are not to come into contact with the hose rupture valve because otherwise they are subject to thermal damaging. Ensure that standards EN 563 and EN 982 are observed.



- 1 Pump
- 2 Main control device
- 3 Pilot control unit
- 4 Hose rupture valve
- 5 Cylinder

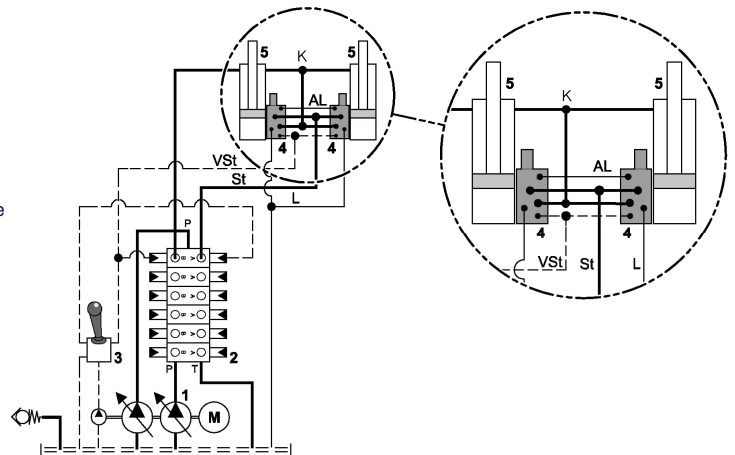

6.3 Installation - space

- Observe the connection labels
- Observe the strength category and torsional torque of the clamp bolts
- Do not damage seals and flange surface
- The air must be exhausted from the hydraulic system
- Observe the recommended installation screws

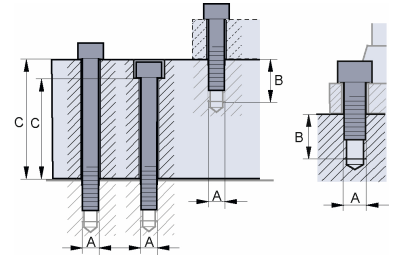

	Thread A	Thread D	Strength class	Thread deep B (mm)	Tightening torque Installation Valve (Nm)	Tightening torque SAE flange (Nm) DIN ISO 6162-2, SAE J518/2	C (mm)
SAE 3/4"	M10	M10x1,5	10.9	16,5	71	70	99,5
SAE 1"	M12	M12x1,75	10.9	21,5	123	130	119,5
SAE 1 1/4"	M14	M14x2	8.8	23,5	123	130	117,5

6.4 Setting „opening pressure“

The opening start of the load control valve is set in the factory according to type code. A setting during startup is not necessary and, for safety purposes, may only be performed by trained technicians using suitable measuring means.

The setting of the opening start, that is the level of the pilot control pressure, from which the load control valve opens to lower the cylinder, is set on the spring cap. Depending on the manufacture date of the load control valve, there are two versions of the setting:

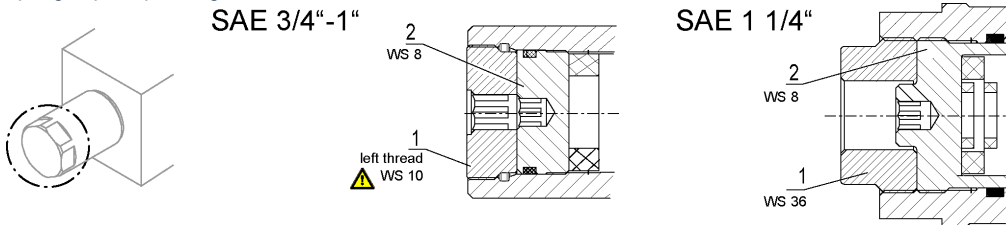

ATTENTION During operation, the valve can heat up to the oil temperature.

- Remove seal (factory status).
- Loosen the AF10 (1) counter nut, left-hand thread (Locknut completely screw out at 3/4" + 1" version)
- The opening start of the hose rupture valve must be approximately 0.5 bar above the opening start of the main control unit spool.
- **Increase:** Turn the set-screw AF8 (2) clockwise.
- **Decrease:** Turn the set-screws AF8 (2) counter-clockwise.
- An adjustment of 1mm thread corresponds a variation of the opening pressure to 2,9 bar.
- Tighten the counter nut (1).

6.5 Setting Pressure limitation

The pressure limitation of the load control valve is set in the factory according to type code. A setting during startup is not necessary and, for safety purposes, may only be performed by trained technicians using suitable measuring equipment.

The maximum operating pressure of the pressure valve depends on the maximum operating pressure of the machine. Observe the technical data. The pressure valve is in one of the indicated positions.



ATTENTION

During operation, the valve can heat up to the oil temperature.

- Undo the counter nut AF19 (1).
- The operating pressure is set up (see table).
- Increase: Turn the set-screw AF5 (2) clockwise.
- Decrease: Turn the set-screws AF5 (2) counter-clockwise.
- 1 revolution corresponds with 84 bar
- Settings over 420 bar (DIN ISO 6162-2, SAE J518/2 (CODE62)) are not permissible
- Tighten the counter nut AF19 (1).

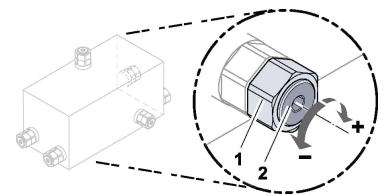

6.6 Setting Maximum lowering speed

The setting of the lowering speed limit (if present) also takes place on the spring cap unit. This setting can only be made when the opening pressure has been set correctly.

- Undo the counter-nut (1).
- Screw in the set-screws (4) clockwise **until the stop position is detected.**
- **After that:**
- Turn the set-screw (2) counter-clockwise until the desired maximum lowering speed is reached.
- **Notice**
- For SAE 3/4" und SAE 1" Version:
- Setting screw (2) at 6 mm unscrewed means maximum lowering speed, one revolution = 1mm. (Please do not unscrew further)
- Für SAE 1 1/4" Version:
- Setting screw (2) at 12 mm unscrewed means maximum lowering speed, one revolution = 1mm. (Please do not unscrew further)
- By screwing the setting screw (2) in, the load control valve is limited in opening travel, which sets the lowering speed.
- Tighten counter nut (1), tightening torque 30 Nm.

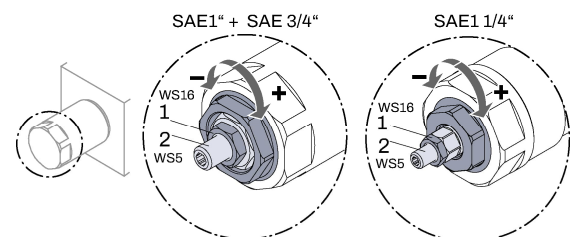

6.7 Dimensions

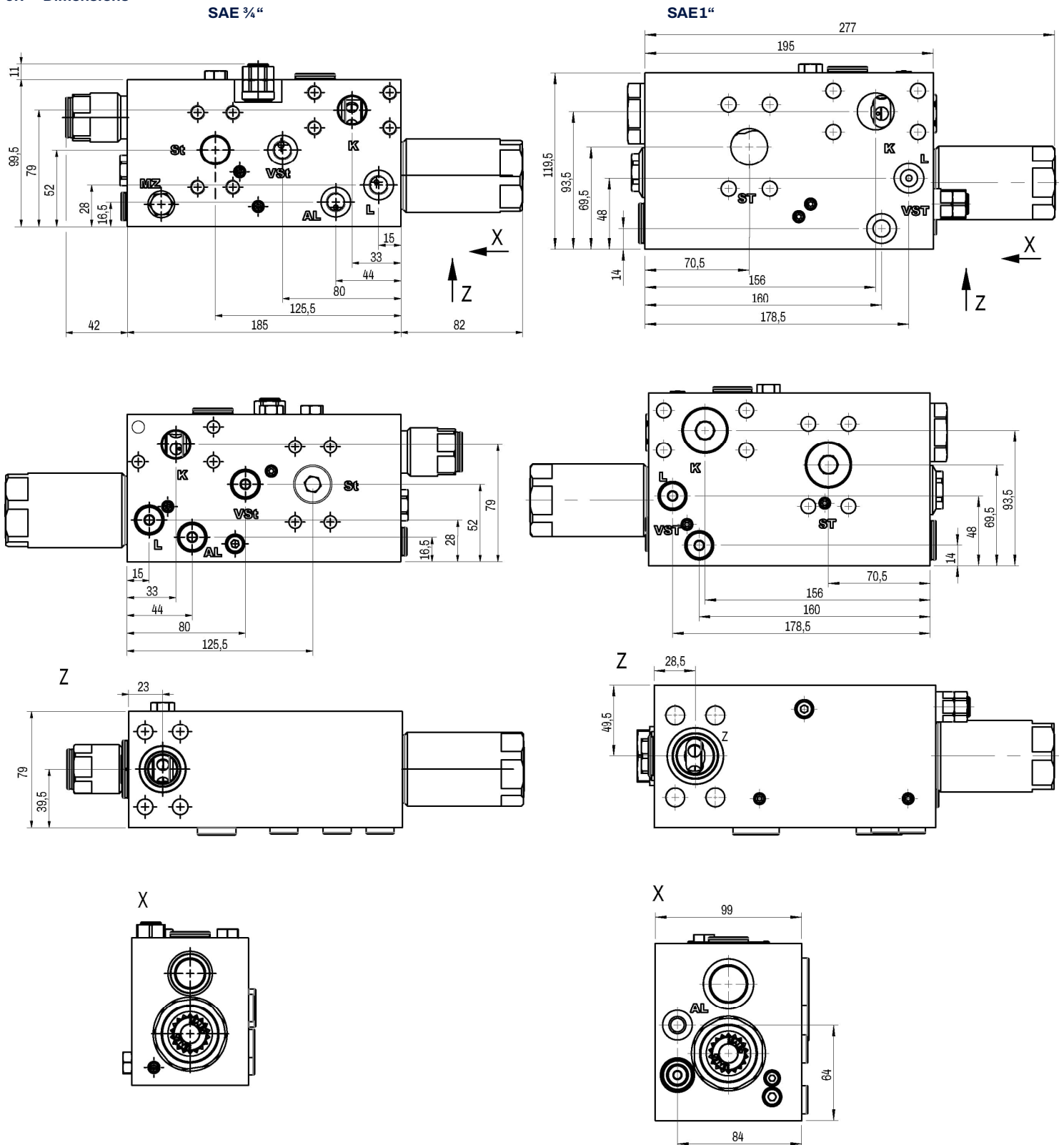

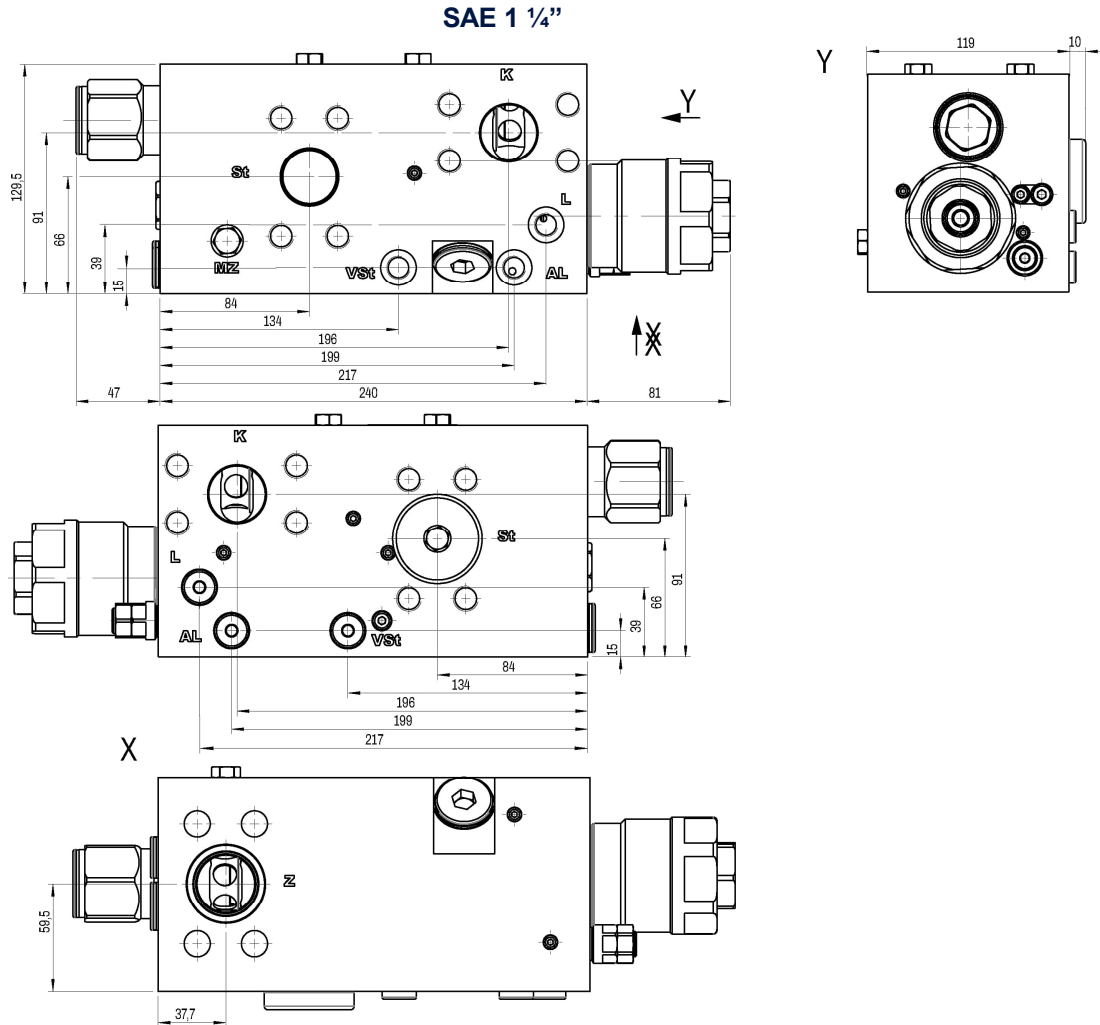

7 Notes, Standards and Safety Requirements

7.1 General remarks

- The views in drawings are shown in accordance with the European normal projection variant
- A comma (,) is used as a decimal point in drawings
- All dimensions are given in mm



7.2 Standards

The load control valve complies with standards:

- DIN 24093
- ISO 8643
- EN 474

The following standards are to be observed because of the surface temperatures on the load control valve:

- EN 563, Temperatures on surfaces that can be touched.
- EN 982, Safety-technical requirements for fluid-technical systems and their components.

7.3 Safety requirements

- WESSEL-HYDRAULIK GmbH guarantees utilization of standard and proven safety principles in accordance with ISO 13849-2: 2003, Tables C.1 and C.2 for the construction of the valve described here.
- WESSEL-HYDRAULIK GmbH has a certified quality management system in accordance with DIN EN ISO 9001.
- The MTTFd value can be adopted from machine manufacturers with 150 years of experience for the described valve!
- Note: The user is therefore responsible for complying with the fundamental and proven safety principles according to ISO 13849-2: 2003, Tables C.1 and C.2 for the implementation and operation of the hydraulic component!

8 Accessories