

Table of contents

1	Product Description	2
1.1	Applicaton	2
1.2	Mounting (location)	2
2	Function	2
2.1	Characteristics	2
2.2	Adjustment options	2
3	Technical Data	3
4	Order information	3
5	Description of Characteristics in Accordance with Type Code	4
5.1	Variant	4
5.2	Anschlüsse	Fehler! Textmarke nicht definiert.
5.3	Spool	4
5.4	Pressure Setting	4
5.5	Actuation	4
5.6	Opening pressure	4
5.7	Setting Compensation	4
5.8	Lowering speed adjustable	4
6	Installation	4
6.1	General remarks	4
6.2	Connection recommendations	4
6.3	Installation - space	5
6.4	Setting „opening pressure“	5
6.5	Setting Pressure limitation	5
6.6	Setting Maximum lowering speed	5
7	Notes, Standards and Safety Requirements	7
7.1	General remarks	7
7.2	Standards	7
7.3	Safety requirements	7
8	Zubehör	Fehler! Textmarke nicht definiert.

1 Product Description

The load control valve prevents uncontrolled cylinder movement in the event of a burst pipe or tube. WESSEL load control valves stand out because of their sensitivity and the direct joystick action transfer. The load control valve in the variant 4K (compact variant) is also suitable for the smallest installation spaces.

Area of application: Telescope cylinder of mobile cranes, excavators, wheel loader
 Connection size(s): SAE 3/4", SAE 1", SAE 1 1/4" CODE 62
 Flow volume range: up to 400 l/min
 Maximum pressure: 420 bar

1.1 Application

Load control valves are required in different countries when construction machines perform lifting activities. They also serve for an exact and stable positioning of the boom and enable sensitive and even movement processes. Load control valves can compensate for leakages on the main control valves in older construction machines.

1.2 Mounting (location)

The load control valve is installed in the line to be protected between the main control valve and the hydraulic cylinder and is flanged directly on the cylinder. Additional pipework and piping between load control valve and cylinder is not permissible

2 Function

The load control valve is closed and leakage free in the idle position (Z → ST). The cylinder cannot lower. When deploying the cylinder (ST → Z), the hydraulic fluid is fed to the cylinder via a check valve.

Pilot control pressure in the VSt connection uses control surfaces to open the load control valve piston against a pressure spring and introduces a jolt-free lowering movement. As the pilot control pressure continues to increase, the entire control cross-section of the load control valve piston is released and the maximum lowering speed is reached. If a hose or pipe breaks, the load control valve controls the maximum lowering speed to the setting defined with the control lever and the maximum specified lowering speed is thereby not exceeded. By moving the control lever into its neutral position further lowering is prevented. The load control valve piston is load-compensated so that no closing force from the return pressure affects the load control valve piston.

The secondary pressure valve is connected with connection Z and opens up to connection VSt when the permanently defined maximum pressure is achieved, which opens the load control valve piston and allows pressure to be decreased from Z to St. A downstream pressure restriction valve is required if the main directional control valve has a closed central position (A).

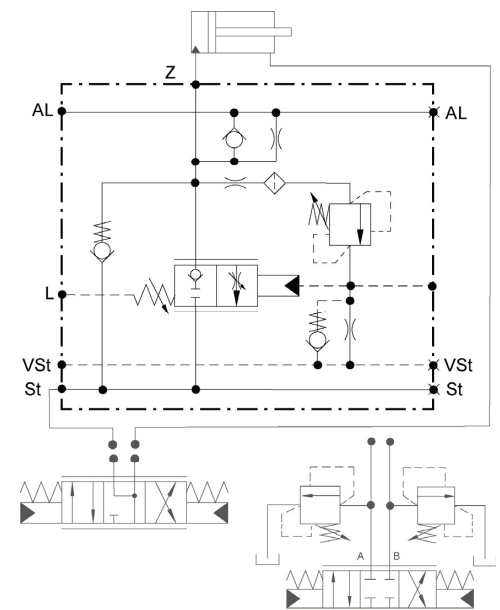

2.1 Characteristics

- Meets the prerequisites of standards: DIN24093, ISO 8643, EN 474
- Start opening independent of the load pressure
- Sensitive control with low hysteresis
- Leakage-free
- Load control valve piston pressure-compensated
- Can be flanged directly onto the cylinder connection
- Surge line for parallel operation for the minimization of the cylinder pressure differences with design
- SAE 3/4" & 1 1/4", for size SAE 1" realizable via the connection MZ
- Pressuring limiting valve with upstream filter sieve for protecting the cylinder

2.2 Adjustment options

- Öffnungsbeginn der Rohrbruchsicherung
- Öffnungsbeginn des Druckbegrenzungsventils einstellbar
- Senkgeschwindigkeitsbegrenzung einstellbar (optional)

3 Technical Data

Criterion		Unit	Value		
			SAE ¾"	SAE 1"	SAE 1 ¼"
Z, ST			DIN ISO 6162-2, SAE J518 (CODE62)		
Max. recommend flow	l/min	350	400	600	
Max. operating pressure	bar	420			
Range pressure setting	bar	350			
Pressure setting	bar	250 – 420			
Max. volume flow		siehe Typenschlüssel Merkmal 04: Druckeinstellung			
Weight		siehe Typenschlüssel Merkmal 03: Steuerschieber			
Opening pressure	Kg	5,8	5,4	13.8	
Full opening	bar	6 – 10			
Max. operating pressure	bar	Öffnungsdruck + Lecköldruck + 17			
Connection		Connection sizes		Pmax	
VSt	Vorsteueranschluss	G ¾; ISO 1179-1	bar	50	
Al	Ausgleichsleitung	G ¾; ISO 1179-1	bar	420	
L	Leckölanschluss	G ¾; ISO 1179-1	bar	<1,0	
MSt	Messanschluss	M8x1, ISO 6149-1	bar	350	
Installation position				Any	
Hydraulic fluid		Mineral oil (HL, HLP) conforming with DIN 51524, other fluids upon request			
Hydraulic fluid temperature range		°C	-20 – +80		
Ambient temperature:		°C	< +50		
Viscosity range		mm2/s	2.8 – 500		
Contamination grade		Filtering conforming with NAS 1638, class 9, with minimum retention rate β10≥75			

4 Order information

00	01	02	03	04	05	06	07	08
00	Product group	Load Control Valve Boom						LHB
01	Variant	Compact variant						4K
02	Connections	Cylinder (Main control valve)	SAE ¾" (DIN ISO 6162-2, SAE J518 (CODE62))		SAE 1" (DIN ISO 6162-2, SAE J518 (CODE62))		SAE 1 ¼" (DIN ISO 6162-2, SAE J518 (CODE62))	
			05C		05E		05G	
03	Spool	Design of the spool optimized for the specified volume flow; [l/min]	Versionen SAE 3/4"		nur Version SAE 1"		nur Version SAE 1 ¼"	
			150		150		150	
			200		200		200	
			250		300		300	
			300		300		300	
			350		300		300	
			400		400		400	
			400		500		500	
			600		600		600	
04	Pressure setting	Pressure limiting valve: value refers to a volume flow of 10 l/min	200 bar bis 420 bar, Standard 420 bar		XXX			
05	Actuation	hydraulic proportional, port G1/4						HYP03B
06	Opening pressure	opens at a pilot control pressure as 6 bar to 10 bar, standard 6 bar = 006						XXX
07	Setting compensation	No compensation						00
08	Maximum lowering speed adjustable	No						0
		Yes						1

Different configurations are unfortunately not implementable for technical reasons. Please let us know if you have questions

5 Description of Characteristics in Accordance with Type Code

5.1 Variant

Stepped housing

5.2 Connections

The valves are flanged directly on the cylinder to be protected (connection Z). The supply line from the control valve takes place via the connection ST. Both connections are designed the same size.

5.3 Spool

The control slider is calculated to the maximum desired volume flow (Z → ST). Criterion: Nominal volume flow, in which a pressure loss (Δp) of maximum 50bar is generated (Z → ST)

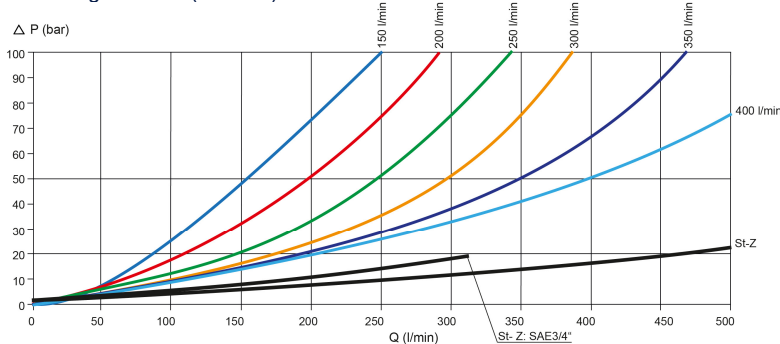

5.4 Pressure Setting

Setting of the pressure restriction valve for securing the cylinder (connection Z). The operating pressure at the ST inlet and at the Z outlet of the valve must not exceed 420 bar for all versions.

5.5 Actuation

Actuation type of the valve. As a rule, this is "hydraulically proportional" connection size of the pilot control connection.

5.6 Opening pressure

Level of the pilot control pressure (connection VST), in which the valve pusher opens and the cylinder begins its lowering movement.

5.7 Setting Compensation

Compensation of the impact of load pressure on the lowering speed. The setting is performed in the factory and cannot be changed.

No compensation: The load pressure had no impact on the opening cross-section of the hose rupture valve. Higher load pressure – higher lowering speed

5.8 Lowering speed adjustable

In addition to the design of the control spool for a maximum volume control, the lowering speed can be further limited by this setting.

6 Installation

6.1 General remarks

- Observe all installation and safety information of the construction machine manufacturer.
- Only technically permitted changes are to be made on the construction machine.
- The user has to ensure that the device is suitable for the respective application.
- Application exclusively for the range of application specified by the manufacturer.
- Before installation or dismantling, the hydraulic system is to be depressurized.
- Settings are to be made by qualified personnel only.
- May only be opened with the approval of the manufacturer, otherwise the warranty is invalidated.
- The included connection recommendations are not guaranteed. The functionality and the technical specifications of the construction machine must be checked.

6.2 Connection recommendations

CAUTION! Hydraulic hoses are not to come into contact with the hose rupture valve because otherwise they are subject to thermal damaging. Ensure that standards EN 563 and EN 982 are observed.



- 1 Pump
- 2 Main control device
- 3 Pilot control unit
- 4 Hose rupture valve
- 5 Cylinder

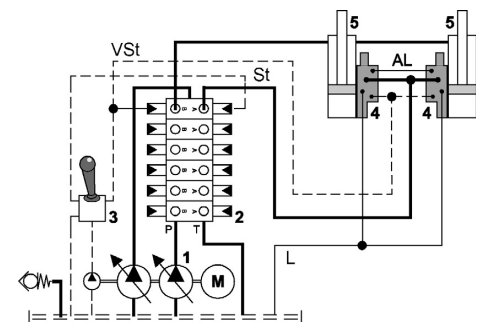

6.3 Installation - space

- Observe the connection labels
- Observe the strength category and torsional torque of the clamp bolts
- Do not damage seals and flange surface
- The air must be exhausted from the hydraulic system
- Observe the recommended installation screws

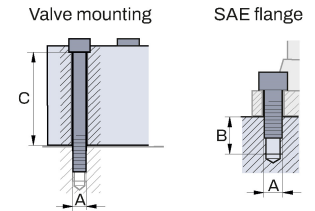

	Thread A	Strength class	Thread deep B (mm)	Tightening torque Installation Valve (Nm)	Tightening torque SAE flange (Nm) DIN ISO 6162-2, SAE J518/2	C (mm)
SAE 3/4"	M10	10.9	16,5	71	70	78
SAE 1"	M12	10.9	21,5	123	130	78,6
SAE 1 1/4"	M14	8.8	23,5	195	150	97,5

6.4 Setting „opening pressure“

The opening pressure of the load control valve is set in the factory according to type code. A setting during startup is not necessary and, for safety purposes, may only be performed by trained technicians using suitable measuring equipment.

The setting of the opening pressure, that is the level of the pilot control pressure, from which the load control valve opens to lower the cylinder, is set on the spring cap unit. Depending on the manufacture date of the hose rupture valve, there are two versions of the setting in the cycle:

without setting the max. Lowering speed

with setting the max. Lowering speed

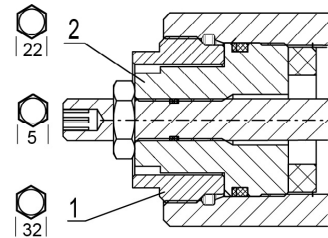
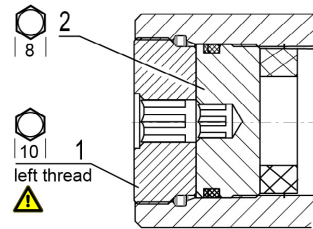
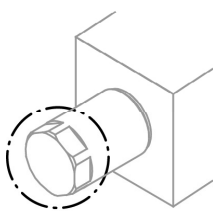

ATTENTION During operation, the valve can heat up to the oil temperature. Remove seal (factory status).

- Loosen the AF10 (1) counter-nut, ATTENTION: left-hand thread
- The opening start of the hose rupture valve must be approximately 0.5 bar above the opening start of the main control unit spool.
- Increase: Turn the set-screw AF8 (2) clockwise.
- Decrease: Turn the set-screws AF8 (2) counter-clockwise.
- An adjustment of 1mm thread corresponds a variation of the opening pressure to 2,9 bar.
- Tighten the counter-nut AF10 (1).

6.5 Setting Pressure limitation

The pressure limitation of the load control valve is set in the factory according to type code. A setting during startup is not necessary and, for safety purposes, may only be performed by trained technicians using suitable measuring equipment.

The maximum operating pressure of the pressure valve depends on the maximum operating pressure of the machine. Observe the technical data. The pressure valve is in one of the indicated positions.



ATTENTION

During operation, the valve can heat up to the oil temperature.

- Undo the counter-nut AF19 (1).
- The operating pressure is set up (see table).
- Increase: Turn the set-screw AF5 (2) clockwise.
- Decrease: Turn the set-screws AF5 (2) counter-clockwise.
- 1 revolution corresponds with 84 bar
- Settings over 420 bar (DIN ISO 6162-2, SAE J518/2 (CODE62)) are not permissible
- Tighten the counter-nut AF19 (1).

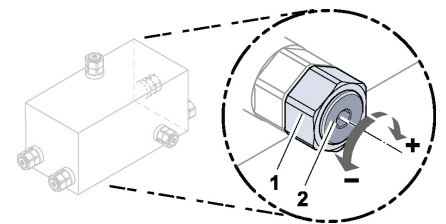

6.6 Setting Maximum lowering speed

The setting of the lowering speed limit (if present) also takes place on the spring cap unit. This setting can only be made when the opening pressure has been set correctly.

- Undo the counter-nut (1).
- Screw in the set-screws (4) clockwise **until the stop position is detected.**
- **After that:**
- Turn the set-screw (2) counter-clockwise until the desired maximum lowering speed is reached.

Notice

- For SAE 3/4" und SAE 1" Version:
- Setting screw (2) at 6 mm unscrewed means maximum lowering speed, one revolution = 1mm. (Please do not unscrew further)
- Für SAE 1 1/4" Version:
- Setting screw (2) at 12 mm unscrewed means maximum lowering speed, one revolution = 1mm. (Please do not unscrew further)
- By screwing the setting screw (2) in, the load control valve is limited in opening travel, which sets the lowering speed.
- Tighten counter-nut (1), tightening torque 30 Nm.

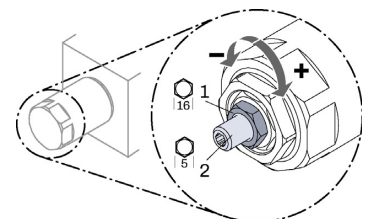

6.7 Dimensions

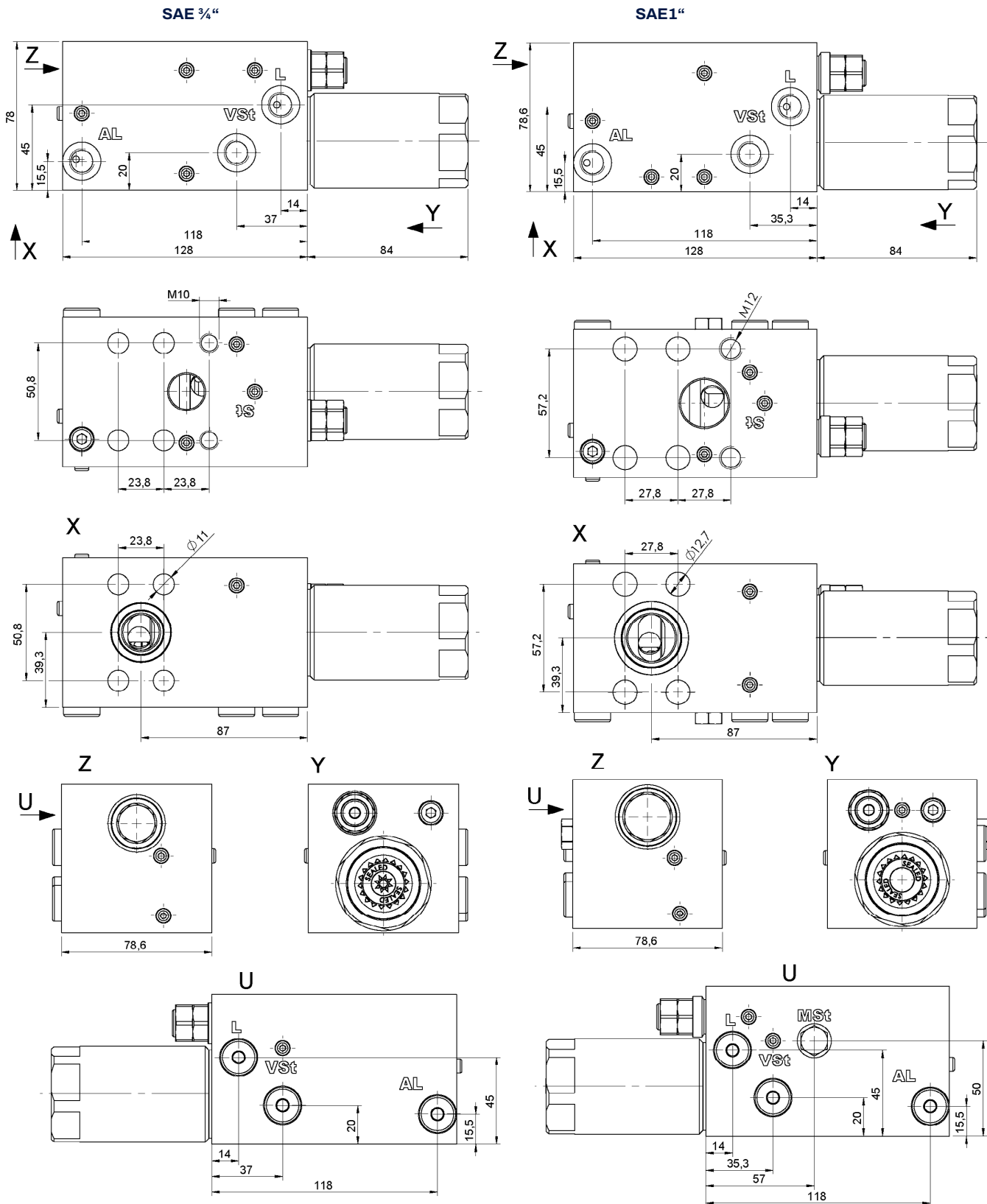

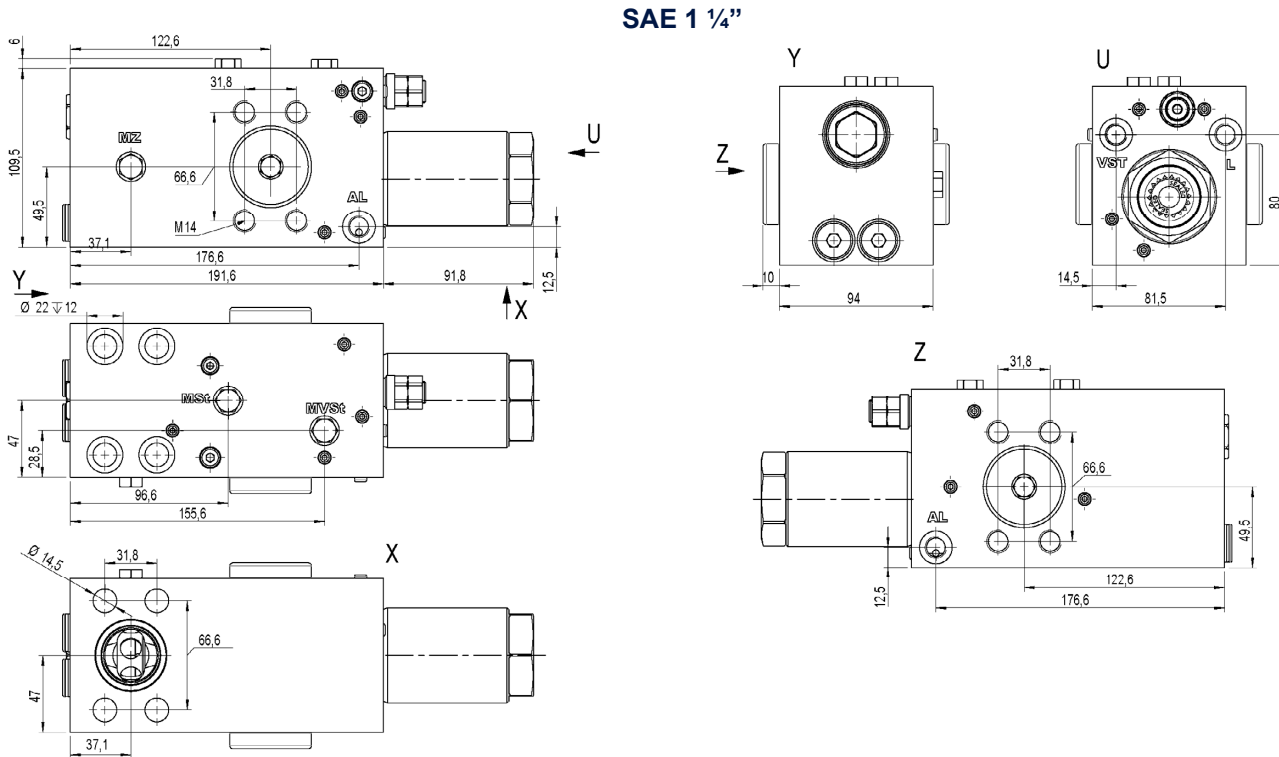

7 Notes, Standards and Safety Requirements

7.1 General remarks

- The views in drawings are shown in accordance with the European normal projection variant
- A comma (,) is used as a decimal point in drawings
- All dimensions are given in mm

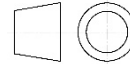

7.2 Standards

The load control valve complies with standards:

- DIN 24093
- ISO 8643
- EN 474

The following standards are to be observed because of the surface temperatures on the load control valve:

- EN 563, Temperatures on surfaces that can be touched.
- EN 982, Safety-technical requirements for fluid-technical systems and their components.

7.3 Safety requirements

- WESSEL-HYDRAULIK GmbH guarantees utilization of standard and proven safety principles in accordance with ISO 13849-2: 2003, Tables C.1 and C.2 for the construction of the valve described here.
- WESSEL-HYDRAULIK GmbH has a certified quality management system in accordance with DIN EN ISO 9001.
- The MTTFd value can be adopted from machine manufacturers with 150 years of experience for the described valve!
- Note: The user is therefore responsible for complying with the fundamental and proven safety principles according to ISO 13849-2: 2003, Tables C.1 and C.2 for the implementation and operation of the hydraulic component!

8 Accessories