



## Table of Contents

<b>1</b>	<b>Product Description</b> .....	<b>2</b>
1.1	Application .....	2
1.2	Mounting location .....	2
1.3	Characteristics .....	2
1.4	Function .....	2
<b>2</b>	<b>Technical Data</b> .....	<b>3</b>
<b>3</b>	<b>Ordering Information</b> .....	<b>4</b>
<b>4</b>	<b>Description of Characteristics in Accordance with Type Code</b> .....	<b>5</b>
4.1	Characteristic 1: Variant .....	5
4.2	Characteristic 2: Connection T torque control spring.....	5
4.3	Characteristic 3: Connection V torque control spring.....	5
4.4	Characteristic 4: Nominal volume flow.....	5
4.5	Characteristic 5: Pressure setting .....	5
4.6	Characteristic 6: Damping.....	6
4.7	Characteristic 7: Setting Pressure valve output.....	6
<b>5</b>	<b>Installation</b> .....	<b>7</b>
5.1	General remarks .....	7
5.2	Connection recommendations .....	7
5.3	Installation - space .....	7
5.4	Dimensions .....	7
<b>6</b>	<b>Notes, Standards and Safety Requirements</b> .....	<b>8</b>
6.1	General remarks .....	8
6.2	Standards.....	8
<b>7</b>	<b>Accessories</b> .....	<b>8</b>

## 1 Product Description

WESSEL lowering brake check valves secure the booms against unintentional extending and retracting of your cylinder during hose or pipe breaks. WESSEL lowering brake check valves are design free of oil leakage and thereby hold the cylinder in a defined position.

### 1.1 Application

Lowering brake check valves for vibration sensitive cylinder applications with flow rates up to 60 l/min and maximum pressures up to 450 bar. Multi-unit poles/booms, which are moved by cylinder, often tend to oscillate. Application examples are concrete placing booms or aerial work platforms. In case of insufficient damping, this can also be caused by the control of a cylinder. Due to the excellent damping characteristics of these valves, vibration can be avoided.

### 1.2 Mounting location

The valve is installed onto the two cylinder connection of the boom that requires securing.



### 1.3 Characteristics

- Leakage free seat in hardened steel housing
- Load pressure independent opening of the control valve
- Cylinder tailored throttle cross sections of the control valve
- High damping characteristics
- Separate pressure limiting valve: Opening point is selectable independent of the DBV setting.
- Directly flanged to the cylinder

### 1.4 Function

In general, both cylinder connections are secured with a lowering brake valve type LHC. The hydraulic oil from the control valve flows via the check valve to the cylinder connection. The pressure rises since the opposite side is still closed off. As soon as the opening pressure for the lowering brake valve slide reaches the opposite side, it is opened and the oil can flow from the second cylinder chamber via the control valve to the tank. A path-dependent and direction-dependent dampening causes a vibration-free movement of the actuated cylinder.

The pressure limiting valve is arranged parallel to the lowering brake valve slide. This can relieve in one embodiment to a separate tank connection, or in another embodiment to the control line.

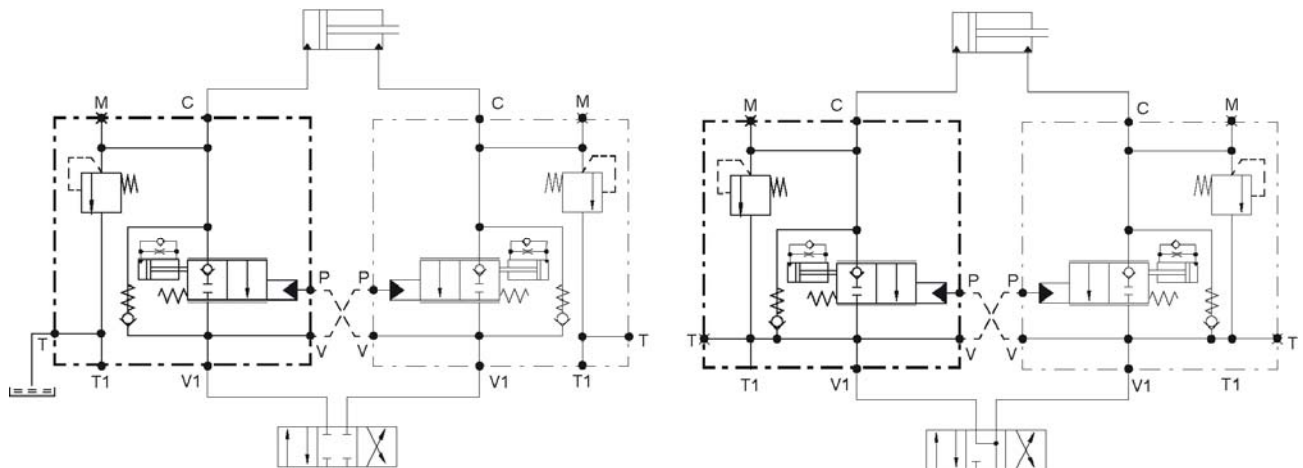

## 2 Technical Data

Criterion	Units	Value
Cylinder connection C		M22x1.5 – pmax < 450bar
Max. operating pressure	bar	450
Max. volume flow	l/min	60
Weight	kg	2.7
Opening pressure of lowering brake valve	bar	32 bar
<b>Connection</b>		
T,V		see type code
T1,V1		G 3/8, ISO 1179-1, T1 pmax < 10bar, V1 pmax < 350bar
P		G 1/4, ISO 1179-1, pmax < 350bar
M		G 1/4, ISO 1179-1, pmax < 450bar

Criterion	Units	Value
Hydraulic fluid		Mineral oil (HL, HLP) conforming with DIN 51524, other fluids upon request
Pressure fluid temperature range	°C	-20 – +80
Ambient temperature:	°C	-30 – +50
Viscosity range	mm <sup>2</sup> /s	2.8 – 500
Contamination grade		Filtering conforming with NAS 1638, class 9, with minimum retention rate $\beta_{10} \geq 75$

## 3 Ordering Information

<b>LHC</b>	<b>3H</b>							
00	01	02	03	04	05	06	07	08
00	Product group	Load Control Valve Cylinder						<b>LHC</b>
01	Variant	Attachment with a hollow bolt on the cylinder connection						<b>3H</b>
02	Connection T torque control spring		Closed	<b>000</b>				
			AD16S	<b>10R</b>				
			AD12L	<b>10F</b>				
			M14x1.5	<b>01D</b>				
			G 3/8	<b>03C</b>				
			G 1/4	<b>03B</b>				
03	Connection V torque control spring		Closed	<b>000</b>				
			AD12S	<b>10P</b>				
			AD6S	<b>10M</b>				
			AD12L	<b>10F</b>				
			M14x1.5	<b>01D</b>				
			G 3/8	<b>03C</b>				
	G 1/4	<b>03B</b>						
04	Nominal volume flow	Layout of the control valve optimized for the indicated volume flow	10 l/min	<b>10</b>				
			20 l/min	<b>20</b>				
			40 l/min	<b>40</b>				
			60 l/min	<b>60</b>				
05	Pressure setting	Opening/trigger point of the pressure limiting valve	>200 ≤450	<b>XXX</b>				
06	Damping		Standard damping	<b>01</b>				
			High damping	<b>02</b>				
07	Pressure valve outlet to ...	Tank	T1, V1 closed, V, T open	<b>T0</b>				
			T1 closed, V, V1, T open	<b>T1</b>				
		Return line	T, T1, V1 closed, V open	<b>V0</b>				
			T, T1 closed, V, V1 open	<b>V1</b>				

XXX – permanently predetermined characteristics   
 XXX – characteristics selectable by customer   
 ■ available    ○ not available  
 Different configurations are unfortunately not implementable for technical reasons. Please let us know if you have questions

## 4 Description of Characteristics in Accordance with Type Code

### 4.1 Characteristic 1: Variant

Attachment with a hollow bolt on the cylinder connection, thread M22x1.5

### 4.2 Characteristic 2: Connection T torque control spring

The connection to the torque control spring can be selected in the following dimensions:

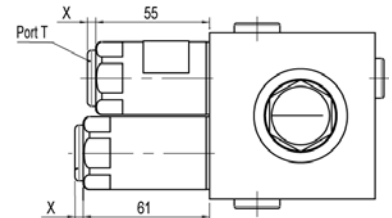
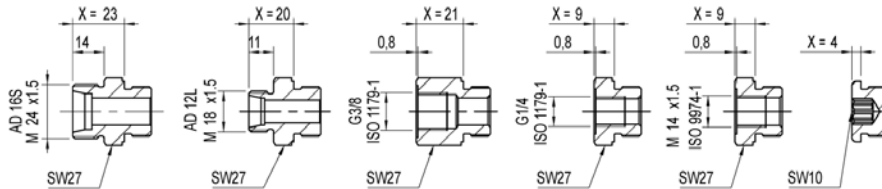

### 4.3 Characteristic 3: Connection V torque control spring

The connection to the torque control spring can be selected in the following dimensions:

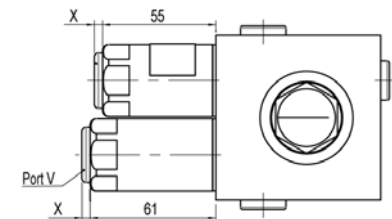
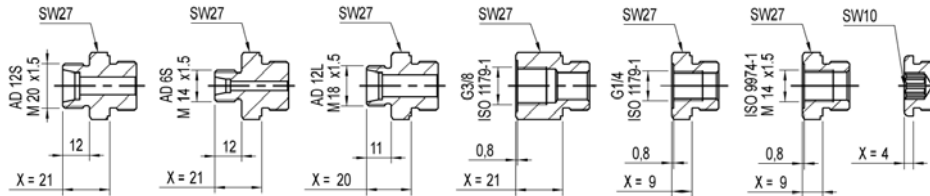

### 4.4 Characteristic 4: Nominal volume flow

Indicates the recommended maximum volume flow from connection C (cylinder) to connection V or V1.

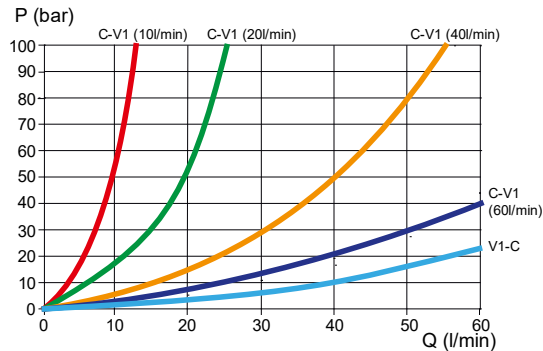

### 4.5 Characteristic 5: Pressure setting

Indicates the set opening start of the pressure limiting valve +/- 5 bar. The value is permanently set and can not be changed.

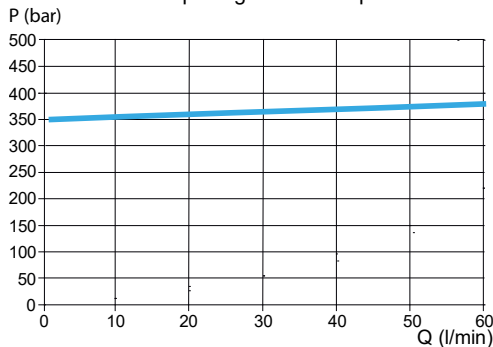

#### 4.6 Characteristic 6: Damping

Using Code 01, the valve opens with the common nozzle damping.

With Code 02 a damping cartridge is installed that first shows a open lift area via a nozzle and thereafter a strong progressive damping.

Closing the valve by removing the inlet pressure is always fast.

#### 4.7 Characteristic 7: Setting Pressure valve output

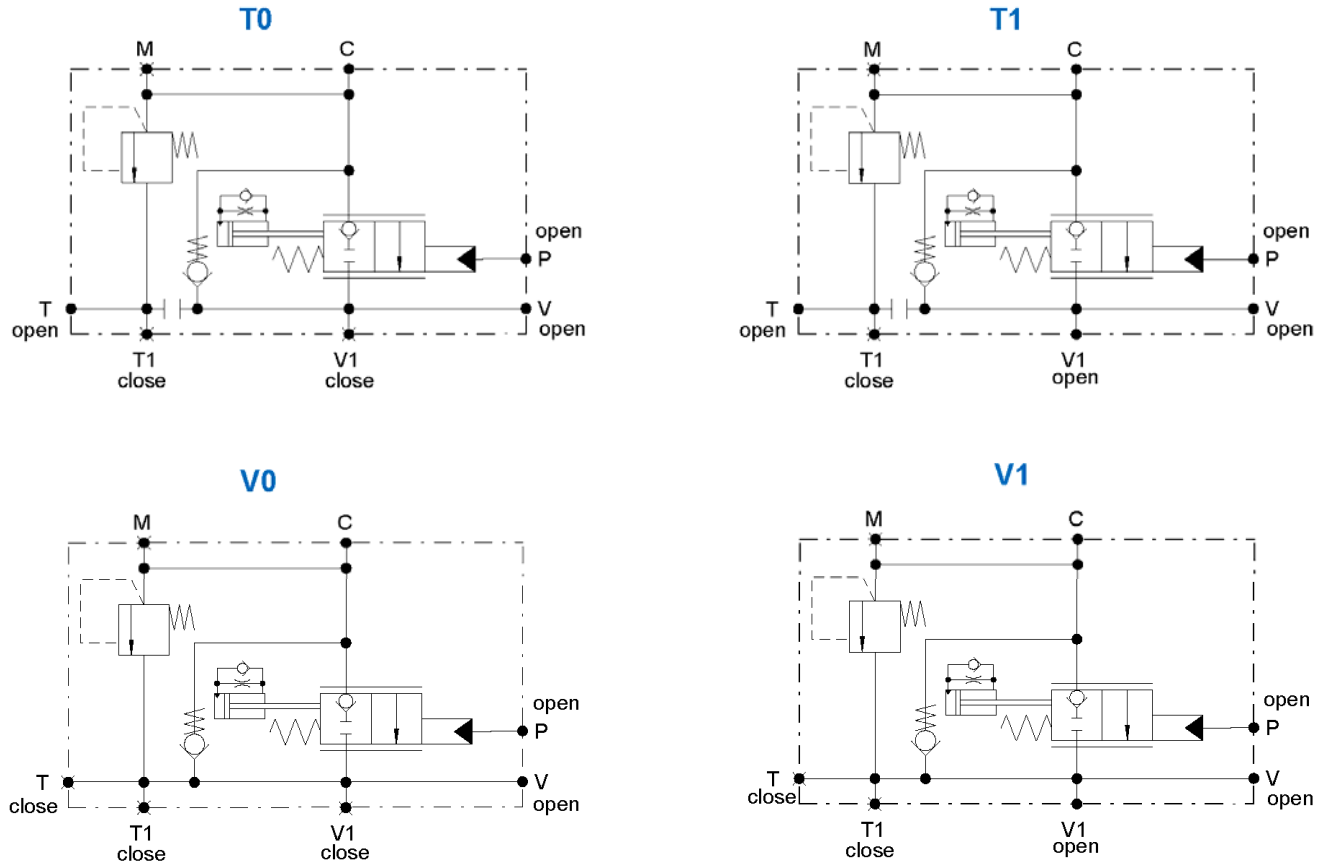

## 5 Installation

### 5.1 General remarks

- Observe all installation and safety information of the construction machine manufacturer.
- Only technically permitted changes are to be made on the construction machine.
- The user has to ensure that the device is suitable for the respective application.
- Application exclusively for the range of application specified by the manufacturer.
- Before installation or dismantling, the hydraulic system is to be depressurized.
- Settings are to be made by qualified personnel only.
- May only be opened with the approval of the manufacturer, otherwise the warranty is invalidated.
- The included connection recommendations are not guaranteed. The functionality and the technical specifications of the construction machine must be checked.

### 5.2 Connection recommendations

Pressure valve outlet to tank

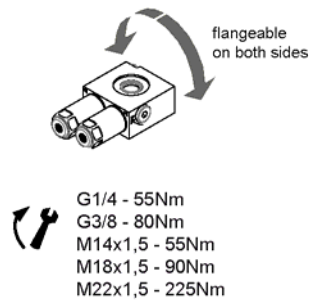
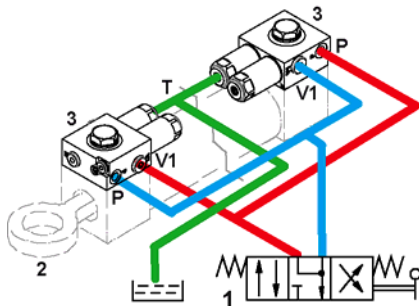

Pressure valve outlet to return flow

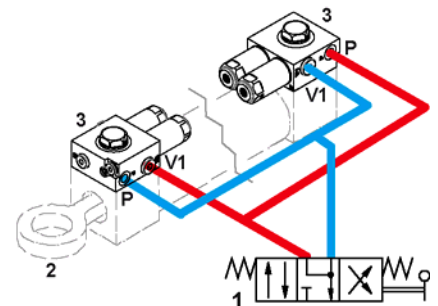

### 5.3 Installation - space

Attachment with a hollow bolt on the cylinder connection

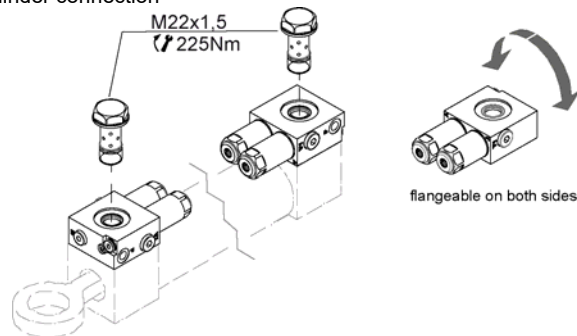

### 5.4 Dimensions

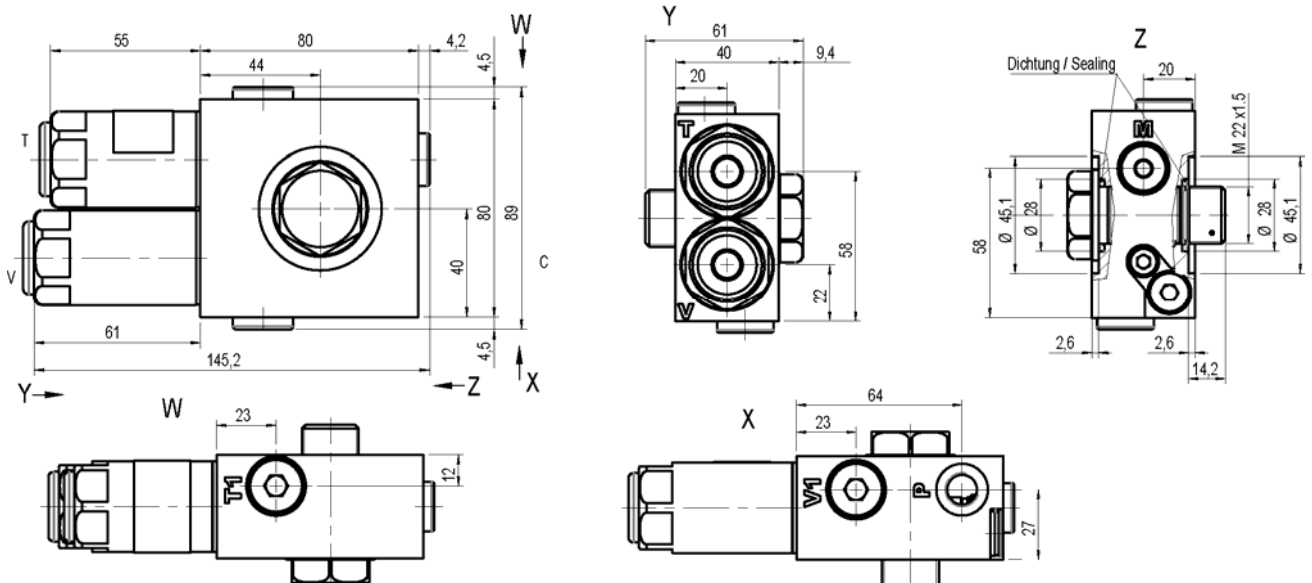

## 6 Notes, Standards and Safety Requirements

### 6.1 General remarks

- The views in drawings are shown in accordance with the European normal projection variant
- A comma ( , ) is used as a decimal point in drawings
- All dimensions are given in mm

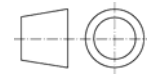

### 6.2 Standards

The following standards must be observed when installing and operating the valve:

- DIN EN ISO 13732-1:2008-12, Temperatures on accessible surfaces
- DIN EN ISO 13849 "Safety of machinery – Safety related parts of control"
  - WESSEL-HYDRAULIK GmbH guarantees utilization of standard and proven safety principles in accordance with ISO 13849-2: 2003, Tables C.1 and C.2 for the construction of the valve described here.
  - WESSEL-HYDRAULIK GmbH has a certified quality management system in accordance with DIN EN ISO 9001.
  - **The MTTFd value can be adopted from machine manufacturers with 150 years of experience for the described valve!**
  - Note: The user is therefore responsible for complying with the fundamental and proven safety principles according to ISO 13849-2: 2003, Tables C.1 and C.2 for the implementation and operation of the hydraulic component!

## 7 Accessories