



Table of Contents

1	Product Description	2
1.1	Application	2
1.2	Mounting location	2
2	Function	2
2.1	Characteristics	2
3	Technical Data	3
4	Ordering Information	3
5	Description of Characteristics in Accordance with Type Code	4
5.1	Variant	4
5.2	Connection T torque control spring	4
5.3	Nominal volume flow	4
5.4	Pressure setting	4
5.5	Damping	4
5.6	Setting Pressure valve output	5
6	Installation	5
6.1	General remarks	5
6.2	Connection recommendations	5
6.3	Installation – space	5
6.4	Dimensions	6
.....		6
7	Notes, Standards and Safety Requirements	6
7.1	General remarks	6
7.2	Standards	6
8	Zubehör	6

1 Product Description

1.1 Application

WESSEL lowering brake check valves secure booms against unintentional extending and retracting of the cylinders during hose or pipe breaks. WESSEL lowering brake check valves are designed leakage-free and thereby hold the cylinder in a defined position.

Multi-section booms, which are moved by cylinders, often tend to oscillate. In case of insufficient damping, oscillations can be caused by the control of a cylinder. Due to the excellent damping characteristics of these valves, vibration can almost be avoided.

Valves of variant 3N are designed as flangeable valves. They are mounted by means of four bolts directly onto the cylinder port to be protected.

1.2 Mounting location

The valve is installed onto the two cylinder connection of the boom that requires securing.

2 Function

In general, both cylinder connections are secured with a lowering brake valve type LHC. The hydraulic oil from the control valve flows via the check valve to the cylinder connection. The pressure rises since the opposite side is still closed off. As soon as the opening pressure for the lowering brake valve slide reaches the opposite side, it is opened and the oil can flow from the second cylinder chamber via the control valve to the tank. A path-dependent and direction-dependent dampening causes a vibration-free movement of the actuated cylinder.

The pressure limiting valve is arranged parallel to the lowering brake valve slide. This can relieve in one embodiment to a separate tank connection, or in another embodiment to the control line.

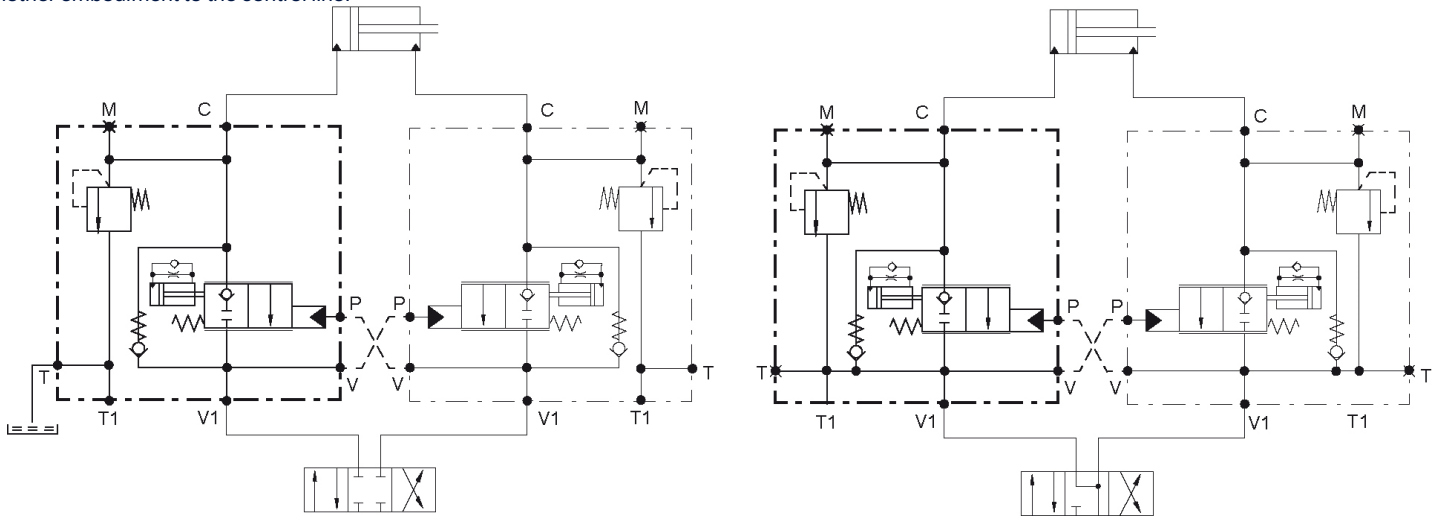

2.1 Characteristics

- Leakage free seat in hardened steel housing
- Load pressure independent opening of the control valve
- Cylinder tailored throttle cross sections of the control valve
- High damping characteristics
- Separate pressure limiting valve: Opening point is selectable independent of the DBV setting.
- Directly flanged to the cylinder

3 Technical Data

Criterion	Units	Value
Cylinder connection C		Ø11 – pmax < 450bar
Max. operating pressure	bar	450
Max. volume flow	l/min	60
Weight	kg	2.7
Opening pressure of lowering brake valve	bar	32 bar
Connection		
T,V		see type code
T1,V1		G 3/8, ISO 1179-1, T1 pmax < 10bar, V1 pmax < 350bar
P		G 1/4, ISO 1179-1, pmax < 350bar
M		G 1/4, ISO 1179-1, pmax < 450bar
Hydraulic fluid		Mineral oil (HL, HLP) conforming with DIN 51524, other fluids upon request
Pressure fluid temperature range	°C	-20 – +80
Ambient temperature:	°C	-30 – +50
Viscosity range	mm2/s	2.8 – 500
Contamination grade		Filtering conforming with NAS 1638, class 9, with minimum retention rate β10≥75

4 Ordering Information

LHC	3N							
00	01	02	03	04	05	06	07	08
00	Product group	Load Control Valve Cylinder						LHC
01	Variant	Attachment with a hollow bolt on the cylinder connection						3N
02	Connection T torque control spring	verschlossen						000
		AD16S						10R
		AD12L						10F
		M14x1,5						01D
		G 3/8						03C
03	Connection V torque control spring	G 1/4						03B
		verschlossen						000
		AD12S						10P
		AD6S						10M
		AD12L						10F
04	Nominal volume flow	M14x1,5						01D
		G 3/8						03C
		G 1/4						03B
		Layout of the control valve optimized for the indicated volume flow	10 l/min				10	
			20 l/min				20	
05	Pressure setting	Opening/trigger point of the pressure limiting valve	40 l/min				40	
			60 l/min				60	
			>200 ≤450				XXX	
06	Damping	Standard damping						01
		High damping						02
07	Pressure valve outlet to ...	Tank	T1, V1 closed, V, T open				T0	
			T1 closed, V, V1, T open				T1	
		Return line	T, T1, V1 closed, V open				V0	
			T, T1 closed, V, V1 open				V1	

Unfortunately, various configurations cannot be implemented for technical reasons. If you have any questions, please contact us for advice.

5 Description of Characteristics in Accordance with Type Code

5.1 Variant

Attachment with a hollow bolt on the cylinder connection, thread M22x1.5

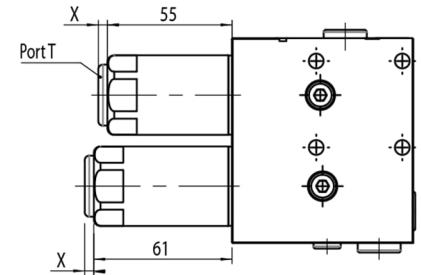
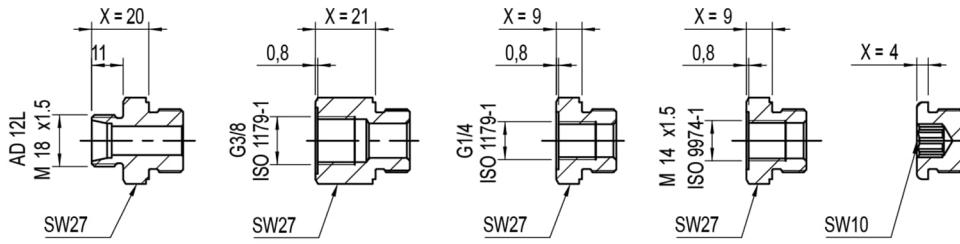

5.2 Connection T torque control spring

The connection to the torque control spring can be selected in the following dimensions:

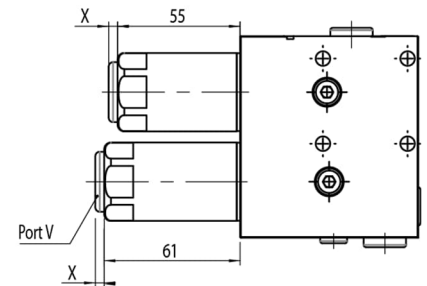
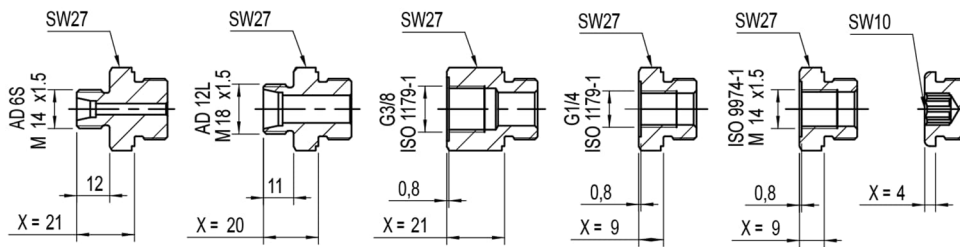

5.3 Nominal volume flow

Indicates the recommended maximum volume flow from connection C (cylinder) to connection V or V1.

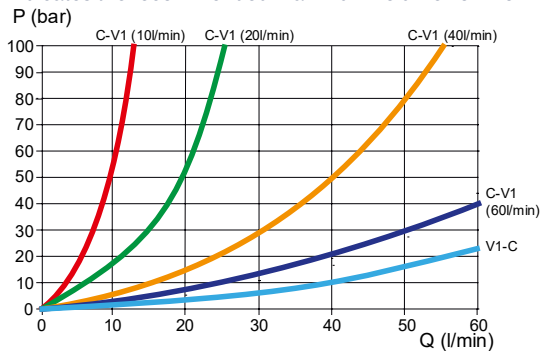

5.4 Pressure setting

Indicates the set opening start of the pressure limiting valve +/-5 bar. The value is permanently set and can not be changed.

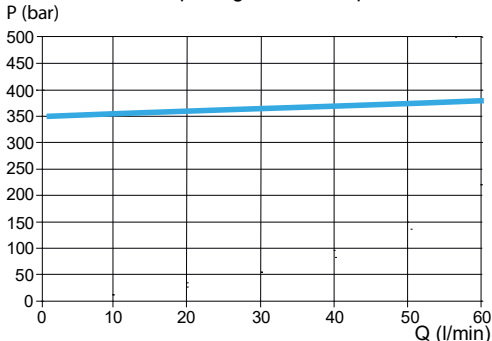

5.5 Damping

Using Code 01, the valve opens with the common nozzle damping.

With Code 02 a damping cartridge is installed that first shows a open lift area via a nozzle and thereafter a strong progressive damping. Closing the valve by removing the inlet pressure is always fast.

5.6 Setting Pressure valve output

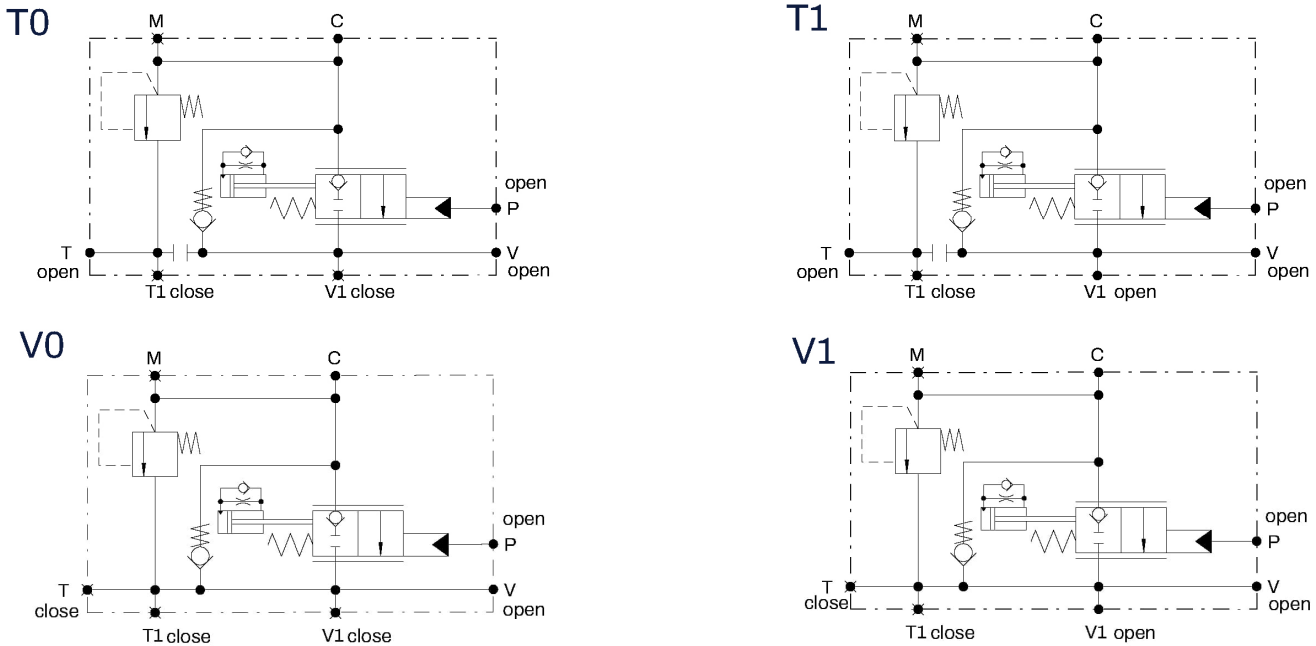

6 Installation

6.1 General remarks

- Observe all installation and safety information of the construction machine manufacturer.
- Only technically permitted changes are to be made on the construction machine.
- The user has to ensure that the device is suitable for the respective application.
- Application exclusively for the range of application specified by the manufacturer.
- Before installation or dismantling, the hydraulic system is to be depressurized.
- Settings are to be made by qualified personnel only.
- May only be opened with the approval of the manufacturer, otherwise the warranty is invalidated.
- The included connection recommendations are not guaranteed. The functionality and the technical specifications of the construction machine must be checked.

6.2 Connection recommendations

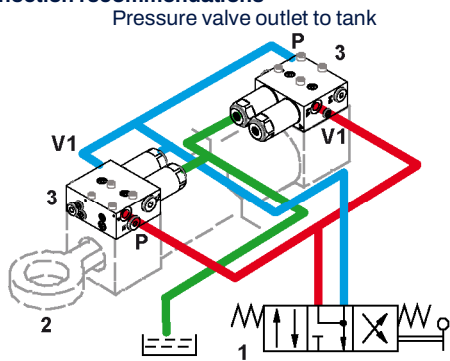

G1/4 - 55Nm
G3/8 - 80Nm
M14x1,5 - 55Nm
M18x1,5 - 90Nm

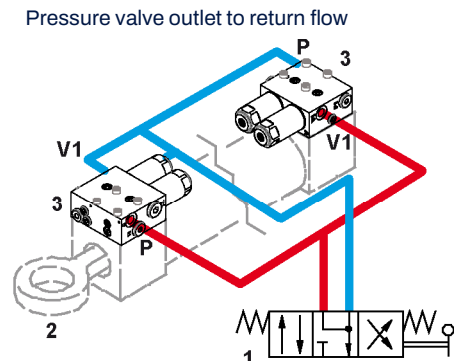

6.3 Installation - space

Attachment with a hollow bolt on the cylinder connection

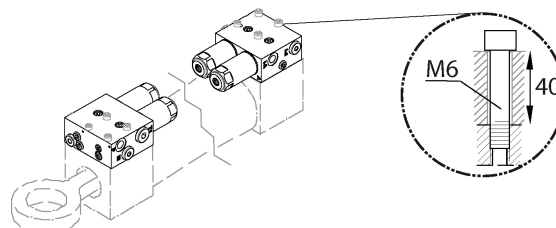

6.4 Dimensions

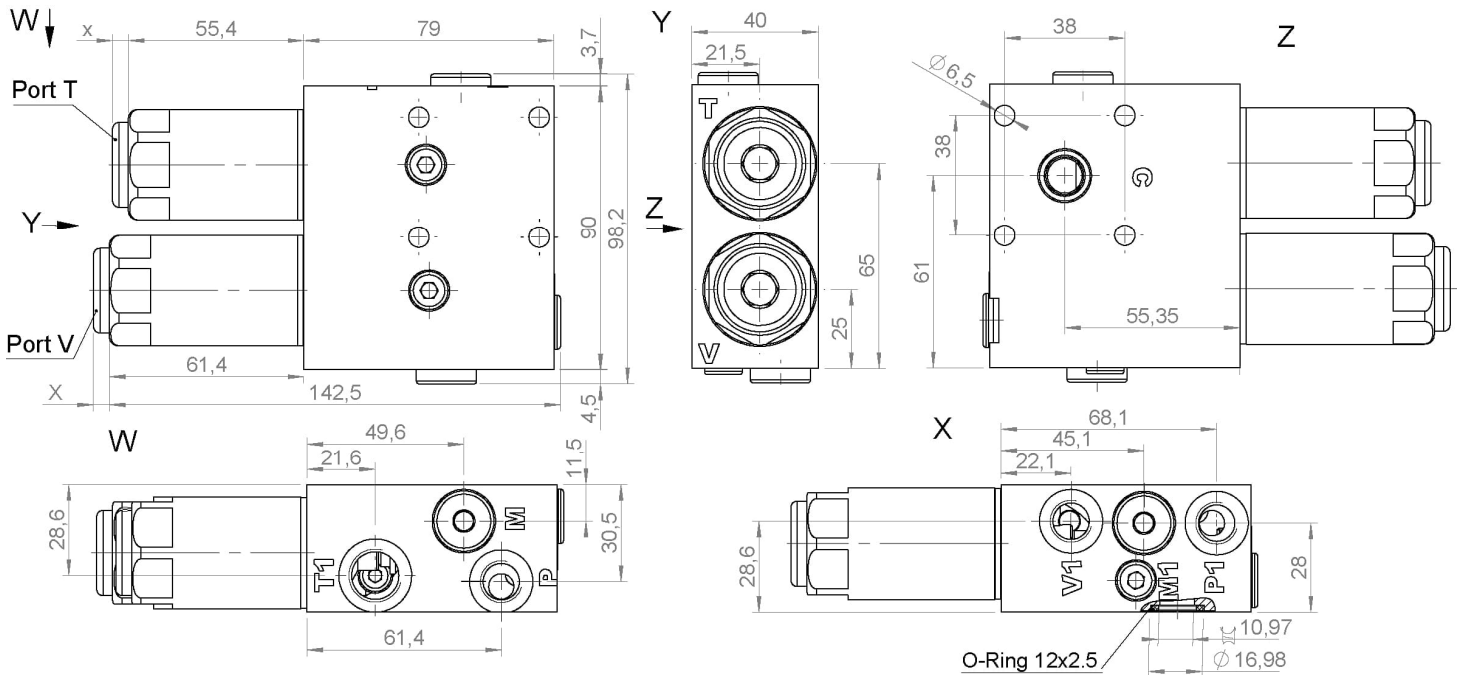

7 Notes, Standards and Safety Requirements

7.1 General remarks

- The views in drawings are shown in accordance with the European normal projection variant
- A comma (,) is used as a decimal point in drawings
- All dimensions are given in mm

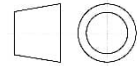

7.2 Standards

The following standards must be observed when installing and operating the valve:

- DIN EN ISO 13732-1:2008-12, Temperatures on accessible surfaces
- DIN EN ISO 13849 "Safety of machinery – Safety related parts of control"
- WESSEL-HYDRAULIK GmbH guarantees utilization of standard and proven safety principles in accordance with ISO 13849-2: 2003, Tables C.1 and C.2 for the construction of the valve described here.
- WESSEL-HYDRAULIK GmbH has a certified quality management system in accordance with DIN EN ISO 9001.
- The MTTFd value can be adopted from machine manufacturers with 150 years of experience for the described valve!
- Note: The user is therefore responsible for complying with the fundamental and proven safety principles according to ISO 13849-2: 2003, Tables C.1 and C.2 for the implementation and operation of the hydraulic component!

8 Zubehör