

Table of Contents

1	Product Description	2
1.1	Application	2
1.2	Mounting location	2
2	Functional description	2
2.1	Characteristics	2
3	Control variants	3
3.1	Control type N (standard)	3
3.2	Control type T	3
3.3	Control type PS	3
3.4	Control type PT	3
3.5	Control type PO	3
3.6	Control type E	3
3.7	Control type D	3
3.8	Control type D with pressure valve PT	4
3.9	Control type D with pressure valve PO	4
3.10	Control type D with pressure valve PS	4
4	Technical Data	4
5	Type Code	5
6	Description of Features according to Type Code	6
6.1	Connection	6
6.2	Control variants	6
6.3	Spool	6
6.4	Spring combination	6
6.5	Pressure setting	6
6.6	Damping (orifice selection)	6
6.7	Opening start	6
6.8	Special features	6
7	Characteristics	6
7.1	Pressure loss, volume flow A → B	6
7.2	For controls with additional damping valve D, D+PO, D+PS, D+PT	6
7.3	Pressure loss, volume flow lowering B → A	7
7.4	Pressure volume flow characteristic curve $p=f(Q)$ Pressure relief valve PS	7
7.5	Pressure volume flow characteristic $p = f(Q)$ secondary pressure relief valve (Special features X1)	7
7.6	Pressure volume flow characteristic $p=f(Q)$ Pilot pressure valve of the controls PO and PT	8
8	Installation	8
8.1	General Instructions	8
8.2	Mounting – Installation Space	8
8.3	Setting the opening pressure	8
8.4	Dimensions	9
9	Notes, Standards and Safety Instructions	10
9.1	General Instructions	10
9.2	Standards	10
9.3	Safety requirements	10
10	Accessories	10

1 Product Description

The new MotionOne lowering brake valve unifies the extensive flexibility through the modular structure, paired with an additional plus through our patented damping cartridge, in order to meet your requirements in terms of vibration damping in any form. The MotionOne is the right choice for precise control and positioning of high loads with volume flows up to 600 l/min / 158,5 gpm.

Lowering brake valves prevent hydraulic consumers from advancing in relation to the incoming volume flow. The MotionOne type valves are particularly suitable for motor, winch and cylinder applications that are prone to vibrations. They shut off the consumer without leakage and the opening takes place independently of the load pressure due to the pressure on the opposite side. Thanks to the various standard damping covers, the valve guarantees maximum flexibility during initial start-up.

1.1 Application

The WESSEL lowering brake valve enables a load to be lifted with little loss using a non-return valve. The valve prevents hydraulic consumers from advancing the incoming oil flow due to pulling loads. The load can be held leak-free. The lowering is regulated.

1.2 Mounting location

The lowering brake valve is flanged directly onto the winch hydraulic motor. It is also possible to use it for cylinder applications.

2 Functional description

The lifting line from the winch main control valve is connected to port A (lifting) of the counterbalance valve.

The lowering line is connected directly to the winch motor, from this line a signal line is connected to port X to open the valve.

To lift the load, the volume flow is routed to the winch via port A through a check valve with little loss. In the idle position, the load is kept leak-free. To lower the load the valve is opened by the increasing pressure at X. The start of opening is adjustable. The lowering of the load is very sensitive and independent of the load pressure. MotionOne lowering brake valves prevent hydraulic consumers from advancing towards the incoming oil flow. This prevents driving loads from advancing in relation to the incoming volume flow. The dampened control of the valve guarantees vibration-free operation.

The only difference between the available variants is the function of the standard damping cover. See chapter 2.

The use of shuttle nozzles ensures a self-cleaning system, which means that no additional inlet filter is required.

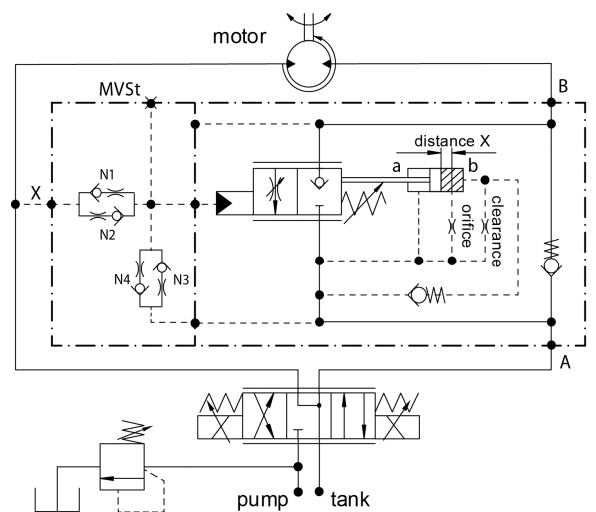
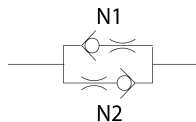

2.1 Characteristics

- Suitable for cylinder, motor and winch applications
- Vibration-free lowering of the load
- Very sensitive characteristics, especially at low speeds and high loads
- Start of opening independent of the load pressure
- Can be flange-mounted directly on SAE
- Available with 10 control variants
- Reliable closing of the lowering brake guaranteed by redundant springs
- Smallest pressure loss (Δp) when lifting the load through the bypass check valve
- Optimal damping behavior due to an additional path-dependent damping system already in the standard N version
- A patented damping cartridge in version D is available for applications that are particularly susceptible to vibrations
- The filter function is achieved via the shuttle valve on the inlet side

3 Control variants

3.1 Control type N (standard)

- Suitable for **light to medium vibration tolerant systems**
- Damping works only in the opening direction
- Different orifice assemblies available
- Easy replacement of the orifice assembly

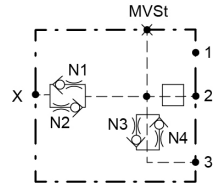

3.2 Control type T

- Suitable for light to medium, **vibration-prone systems**
- The cushioning only works in the opening direction
- Different nozzle configurations possible, see order information
- Easy interchangeability of the nozzle assembly
- The control signal is returned to the tank connection T, thus reducing the lowering pressure

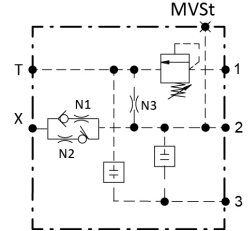

3.3 Control type PS

- Has the **same characteristics as** the standard **type N** damping cover
- **Addition pressure relief valve** protects the consumer against excessive pressure
- The pressure relief valve **opens the main spool**
- Characteristic 6.4

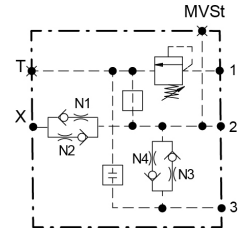

3.4 Control type PT

- Has the **same characteristics as** the standard **type PS** damping cover
- The pressure relief valve **opens to the tank connection**

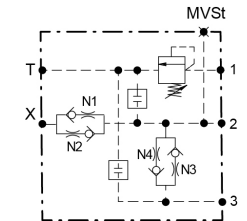

3.5 Control type PO

- Verfügt über die gleichen Eigenschaften **wie** die Ansteuerung **Typ PS**
- Das Druckbegrenzungsventil **öffnet zum Rücklauf A**

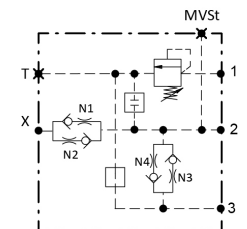
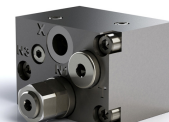

3.6 Control type E

- **Electrically proportional variant**
- Complex applications with electronic control
- This control type enables particularly sensitive control

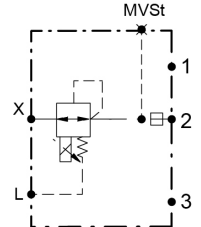

3.7 Control type D

- Construction with patented damping cartridge
- Control signal amplitudes are significantly reduced
- This makes it particularly suitable for vibration-sensitive applications such as hydraulic motors
- Direct response to the control signal
- **Temperature-independent damping**
- The start-up pressure peak is significantly reduced
- Ensures optimal controllability of the machine
- Characteristics curve see 6.2

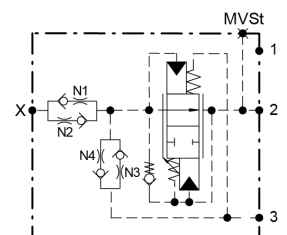

3.8 Control type D with pressure valve PT

- Has the **same** characteristics as the standard **type N and type D**
- **Addition pressure relief valve** protects the consumer
- against excessive pressure
- The pressure relief valve **opens to the tank connection**

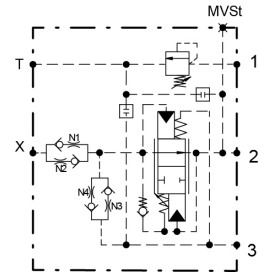

3.9 Control type D with pressure valve PO

- Has the **same** characteristics as the control **type D with pressure valve PT**
- The pressure relief valve **opens to the return line**

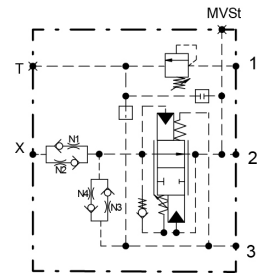

3.10 Control type D with pressure valve PS

- Has the **same** characteristics as the control **type D with pressure valve PT**
- The pressure relief valve **opens the main valve**

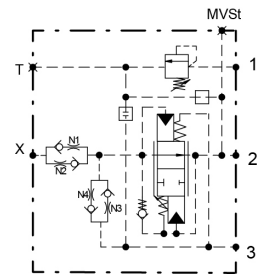
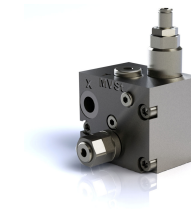

4 Technical Data

Criteria	Unit	Value					
		3/4"	A,B	SAE	3/4"		
A,B	SAE	(DIN ISO 6162-2, SAE J518/2 (CODE62))					
Max. operating pressure B	bar (psi)	420 (6090)					
Max. operating pressure A	bar (psi)	350 (5080)					
Max. pilot pressure at port X	bar (psi)	350 (5080)					
Max. volume flow	l/min (gpm)	350 (92,5)	400 (105,7)	600 (158,5)			
Pressure settings		See type code feature 04: pressure settings					
Weight (control type N)	kg	4,9	5,5	9,3			
				Torques			
A	supply port	SAE 3/4", 1", 1 1/4"	Nm (lbf ft)	70 (51,6)	130 (95,9)	180 (132,8)	130 (95,9)
B	consumer port	SAE 3/4", 1", 1 1/4"	Nm (lbf ft)	70 (51,6)	130 (95,9)	180 (132,8)	130 (95,9)
X	pilot port	G 3/4 ISO 1179-1	Nm (lbf ft)	40 (92,5)			
MA, MB, MVSt	measuring port	G 3/4 ISO 1179-1	Nm (lbf ft)	40 (92,5)			
T	tank port	G 3/4 ISO 1179-1	Nm (lbf ft)	40 (92,5)			
Installation		preferred orientation of spring cap: downward					
Hydraulic fluid		Mineral oil (HL, HLP) conforming with DIN 51524, other fluids on request					
Hydraulic fluid temperature range	°C (F)	-20 – +80 (-4 – 176)					
Ambient temperature:	°C (F)	< +50 (< 122)					
Viscosity range	mm2/s (cSt)	2,8 – 500 (2,8 – 500)					
Contamination grade		Filtering conforming with NAS 1638, class 9, with minimum retention rate β10≥75					

5 Type Code

MotionOne						1		
00	01	02	03	04	05	06	07	08
00	Product group	Counterbalance valve						MotionOne
01	Connection	Motor / Cylinder ISO 6162-2 (SAE J518 Code62) metric	SAE 3/4" (DIN ISO 6162-2, SAE J518/2 (CODE62))					16
			SAE 1" (DIN ISO 6162-2, SAE J518/2 (CODE62))					20
			SAE 1 1/4" (DIN ISO 6162-2, SAE J518/2 (CODE62)) M12					25-M12
					(DIN ISO 6162-2, SAE J518/2 (CODE62)) M14	25-M14		
02	Control variants	Control type N cushioning only works in the opening direction, without pressure valve						N
		Control type T Properties like type N, with additional tank connection for reduced sink pressures						T
		Control type PS Properties like type N, additional secondary pressure valve (return pressure A-dependent) opens the main slide						PS
		Control type PT additional secondary pressure valve 10 l/min (2,6 gpm) (return pressure A-independent) opens to the tank connection						PT
		Control type PO Properties like type N, additional secondary pressure valve 10 l/min (2,6 gpm) (return pressure A dependent) opens to the						PO
		Control type E Electrically proportional variant, without pressure valve 12 / 24VDC A = AMP Junior Timer, D = Deutsch DT04-2P						E12A
								E24A
								E12D
								E24D
Control type D with damping cartridge for vibration-sensitive systems. Without pressure valve						D		
Control type D + pressure valve for PT Properties like type D, additional secondary pressure valve 10 l/min (2,6 gpm) opens to the tank connection						D+PT		
Control type D + pressure valve for PO Properties like type D, additional secondary pressure valve 10 l/min (2,6 gpm) opens to the return						D+PO		
Control type D + pressure valve for PS Properties like type D, additional secondary pressure valve opens the main slide						D+PS		
03	Spool	Standard-Kolben, B → A 200 l/min (52,8 gpm) *					200.1	
		Standard-Kolben, B → A 250 l/min (66 gpm) *					250.1	
		Standard-Kolben, B → A 300 l/min (79,3 gpm) *					300.1	
		Standard-Kolben, B → A 350 l/min (92,5 gpm) *					350.1	
		Standard-Kolben, B → A 400 l/min (105,7 gpm) (nicht für Größe SAE 3/4" erhältlich) *					400.1	
		Standard-Kolben, B → A 500 l/min (132,1 gpm) (nur für Größe SAE 1 1/4" erhältlich) *					500.1	
		Standard-Kolben, B → A 600 l/min (158,5 gpm) (nur für Größe SAE 1 1/4" erhältlich) *					600.1	
04	Spring combination	Applies to nominal size SAE 3/4" and SAE 1": 1 = start of opening from 14bar (200 psi), valve fully opened at 50bar (730 psi) at MVSt. Use for applications with low sink pressures (standard) 2 = start of opening from 14bar (200 psi), valve fully opened at 75bar (1090 psi) at MVSt. Use for higher preloaded applications						X
		Applies to nominal size SAE 1 1/4": 3 = valve fully opened at 50bar (730 psi) at VSt, with an opening start of 14bar (200 psi). Use for higher preloaded applications (standard) 4 = valve fully opened at 35bar (510 psi) at VSt, with an opening start of 14 bar (200 psi). Use for applications with low sink pressures						
05	Pressure setting	Setting off the secondary pressure valve: 150 – 420 bar / 2180 – 6090 psi Variant PS: Setting at 6bar 10l/min(2.6gpm), load pressure 50bar(730psi) below the set value Variant PO + PT: Setting at the start of dripping						xxx
06	Damping (orifice selection)	Is set in the factory: Standard = 1 ZD Ø 0,8 mm (0,0315) in inlet nozzle AD Ø 0,45 mm (0,0177) in outlet nozzle						1
07	Opening start	Opening point 14 bar						14
08	Special features	With pressure valve intermediate plate (up to 80 l/min (21,1 gpm))						X1
		Measuring point MB (only available for SAE 1 1/4 ")						X2
		Measuring point intermediate plate (for MA, MB, MVSt)						X3
		With leakage oil connection L						X4
		Measuring point intermediate plate (for MB)						X5

Some theoretical configurations might be not feasible for technical reasons. For relating questions please ask for our advice.
* measured at 50 bar [725 psi] Δp from B → A

6 Description of Features according to Type Code

6.1 Connection

The valves are flanged directly onto the lifting connection of the winch motor. The lowering line from the main control valve is connected directly to the winch motor and also to the lowering brake valve (port X)

6.2 Control variants

Control Type N	Standard cushioning cover, cushioning only works in the opening direction
Control Type T	Properties like type N, but with an additional tank connection for reduced sink pressures
Control Type PS	Properties like type N, additional pressure relief valve opens the main slide
Control Type PT	Properties like type N, additional pressure relief valve opens to the tank connection
Control Type PO	Properties like type N, additional pressure relief valve opens to the return
Control Type E	Electrically proportional variant
Control Type D	for systems susceptible to vibrations, optimal controllability of the machine
Control Type D + pressure valve for PT	Pressure valve for PT properties like type D, additional pressure valve type PT
Control Type D + pressure valve for PO	Pressure valve for PO Properties like type D, additional pressure valve type PO
Control Type D + pressure valve for PS	Pressure valve for PS Properties like type D, additional pressure valve type PS

6.3 Spool

Please see characteristics 6.3

6.4 Spring combination

Only for the lowering movement, the valve needs to be operated externally. A pressure signal is used for this, which is split off from the lowering line and connected to port X of the lowering brake valve. To lift the load, the volume flow is routed to the winch via port A through a check valve with little loss. In the idle position, the load is kept leak-free. To lower the load, the valve opens with the increasing pressure at X.

6.5 Pressure setting

(Only assigned to control variants PS, PT, PO, D + PS, D + PT, D + PO)

The pressure setting should always keep a sufficient distance to the maximum operating pressure. Pressure relief valves have a hysteresis: It has to be noted that the pressure relief valve only closes at a lower pressure than it had opened. This can lead to uncontrolled lowering when the pressure relief function is triggered with load pressure close to the opening level of the valve.

6.6 Damping (orifice selection)

Inlet and outlet nozzles dampen the opening speed of the lowering brake valve. All MotionOne lowering brake valves also use a way-dependent damping system. For applications that are sensitive to vibrations, the type D control with a patented damping cartridge can be used also. The damping characteristics is shown in curve 6.2. The pressure amplitude of the existing lowering pressure X is significantly reduced and shown in the red characteristic line of the Vst pressure, which enables the load to be lowered without vibrations. Control D is also available with an additional pilot pressure valve in types D + PO, D + PT and D + PS.

6.7 Opening start

Opening start 14 bar

6.8 Special features

- X1 With pressure valve manifold (80 l/min (21.1 gpm))
- X2 measuring point MB (only available for SAE 1 1/4")
- X3 measuring point manifold (for MA, MB, MVSt)
- X4 With leakage port L
- X5 measuring point manifold (for MB)

7 Characteristics

7.1 Pressure loss, volume flow A → B

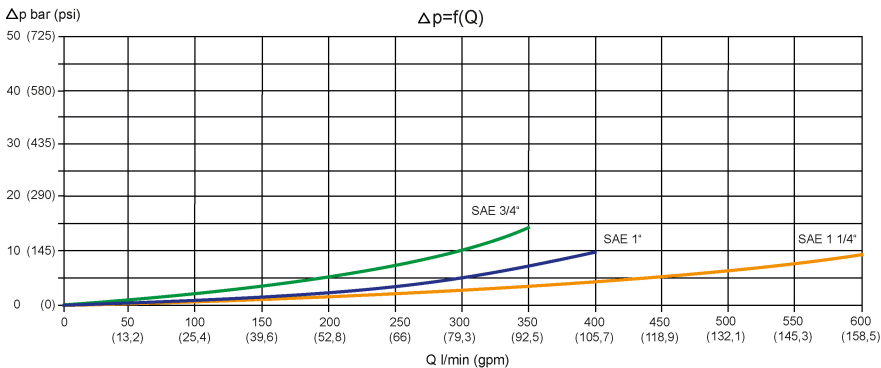

7.2 For controls with additional damping valve D, D+PO, D+PS, D+PT

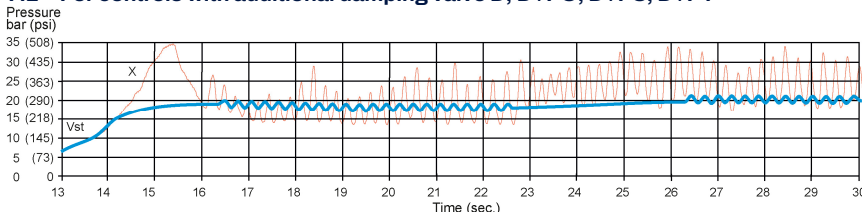

Example of a damped VST characteristic curve from the new patented damping valve. The existing oscillation amplitudes from the control pressure are smoothed according to the set damping.

7.3 Pressure loss, volume flow lowering B → A

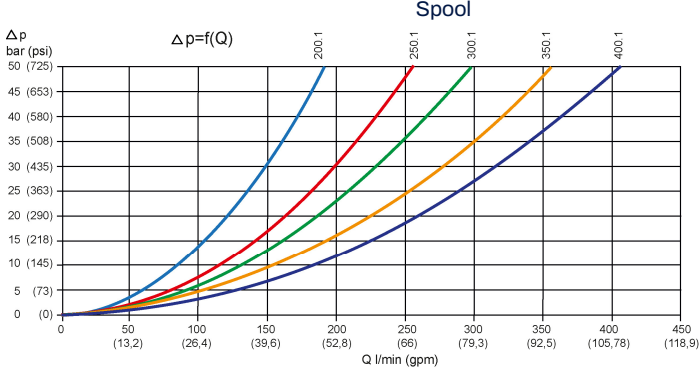

7.4 Pressure volume flow characteristic curve $p=f(Q)$ Pressure relief valve PS

Spring package 50bar, MotionOne SAE 1" and SAE 3/4" with valve tappets 100.316.193.1 and pressure divider circuit (ZD = Ø 0.8mm inlet nozzle, AD Ø 0.45mm outlet nozzle).

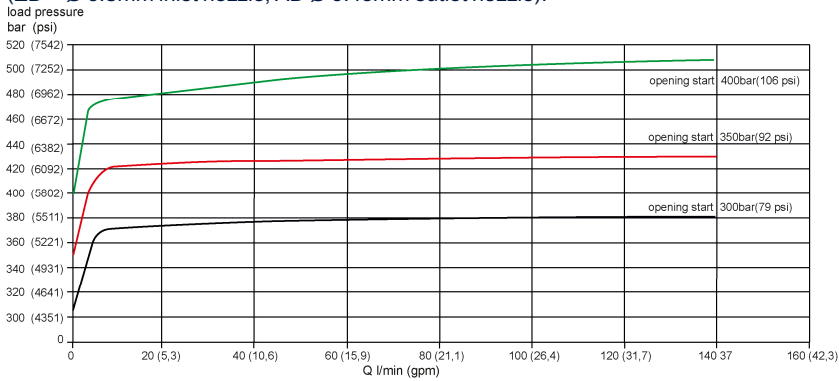

The characteristic depends on the following size:

- spring package
- pressure divider circuit
- valve tappets

Spring package 50bar, MotionOne 1 1/4" with valve tappets 100.316.179.1 and pressure divider circuit (ZD = Ø 0.8mm inlet nozzle, AD Ø 0.45mm outlet nozzle)

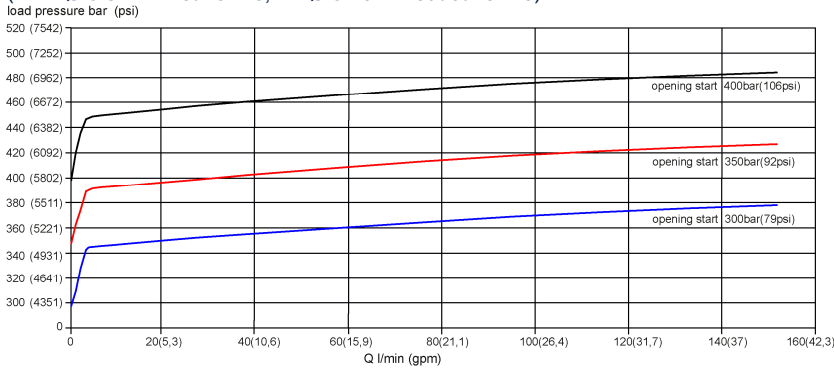

The characteristic depends on the following size:

- spring package
- pressure divider circuit
- valve tappets

7.5 Pressure volume flow characteristic $p = f(Q)$ secondary pressure relief valve (Special features X1)

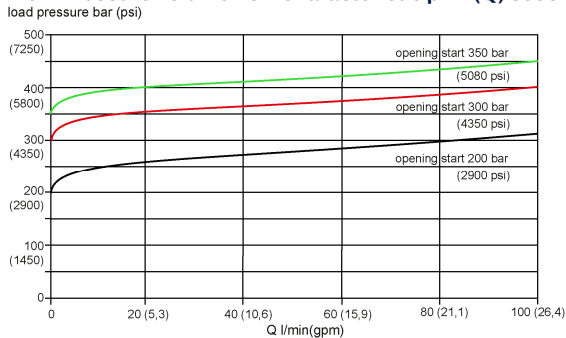

7.6 Pressure volume flow characteristic $p=f(Q)$ Pilot pressure valve of the controls PO and PT

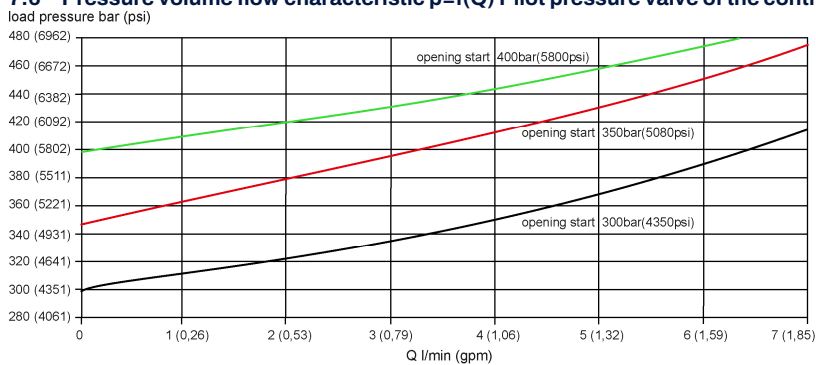

8 Installation

8.1 General Instructions

- Observe all installation and safety information of the construction machine manufacturer.
- Only technically permitted changes are to be made on the construction machine.
- The user has to ensure that the device is suitable for the respective application.
- Application exclusively for the range of application specified by the manufacturer.
- Before installation or deinstallation, the hydraulic system is to be depressurized.
- Settings are to be made by qualified personnel only.
- Opening is only to be performed with the approval of the manufacturer, otherwise the warranty is invalidated.
- The included connection recommendations are not guaranteed. The functionality and the technical specifications of the construction machine must be checked.

8.2 Mounting – Installation Space

- Observe the connection designations
- Observe the strength category and recommended torques (see appendix) of the fastening bolts
- Do not damage seals and flange surfaces
- The air must be exhausted from the hydraulic system

supply port A consumer port B	SAE	Thread A	Thread depth B mm (in)	Torque Nm (lbf ft)	strength category
	SAE ¾" DIN ISO 6162-2-2012	M10	18 (0,71)	70 (51,6)	at least mindestens 10.9
	SAE 1" DIN ISO 6162-2-2012	M12	23 (0,91)	130 (95,9)	
	SAE 1 ¼" wie ISO 6162-2 aber M14 (2011)	M14	23 (0,91)	180 (132,8)	
	SAE 1 ¼" wie ISO 6162-2-2012 - M12	M12	23 (0,91)	130 (95,9)	

8.3 Setting the opening pressure

The opening point of the Load Holding Valve and the pressure limitation is factory set according to type code. A setting during startup is not necessary. The user is responsible for the any changes made to the product.

8.4 Dimensions

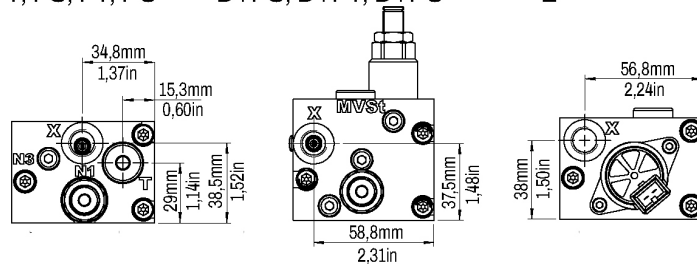
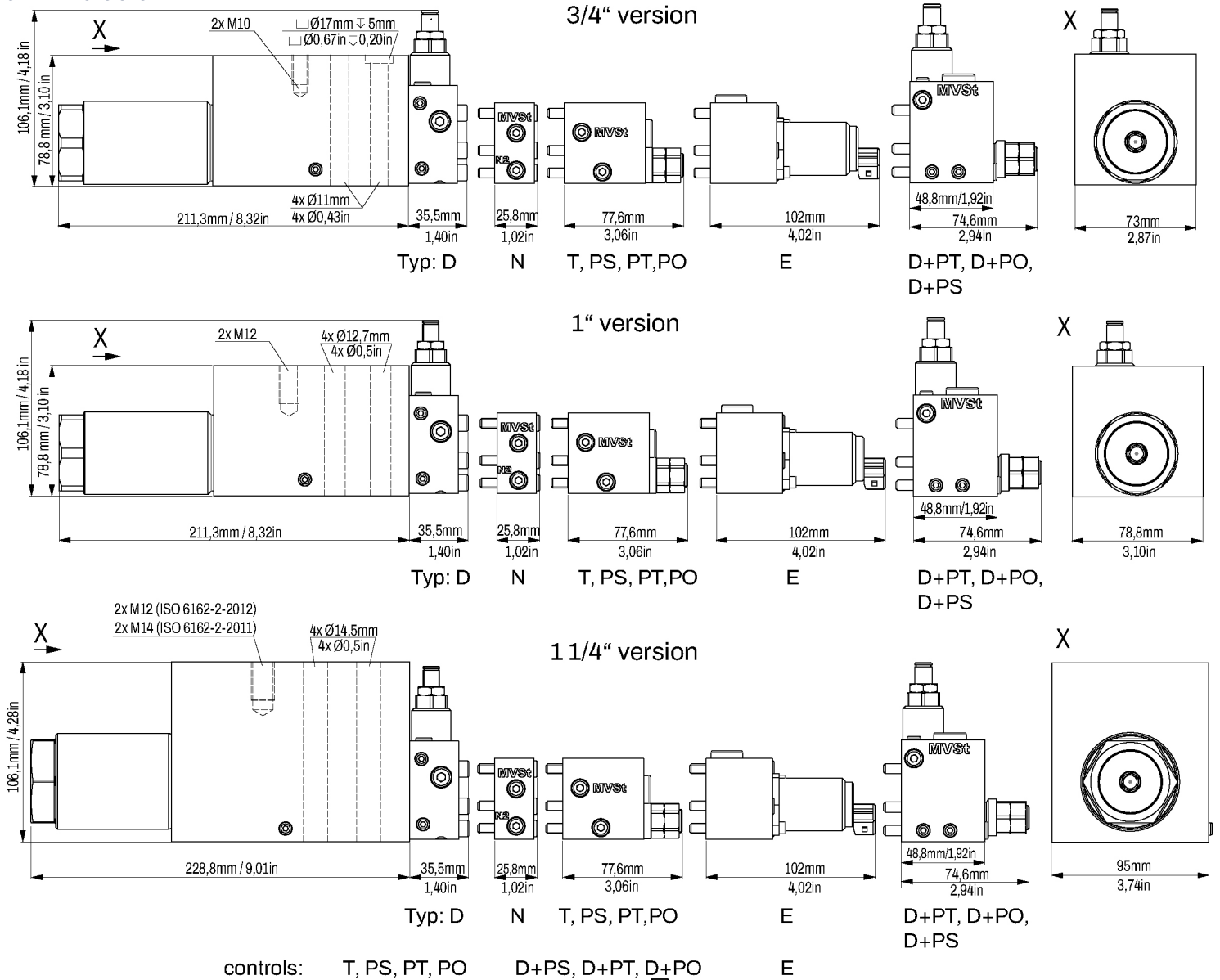

special features:

Measuring point intermediate plate (MB)

Measuring point intermediate plate (for MA, MB, MVSt)

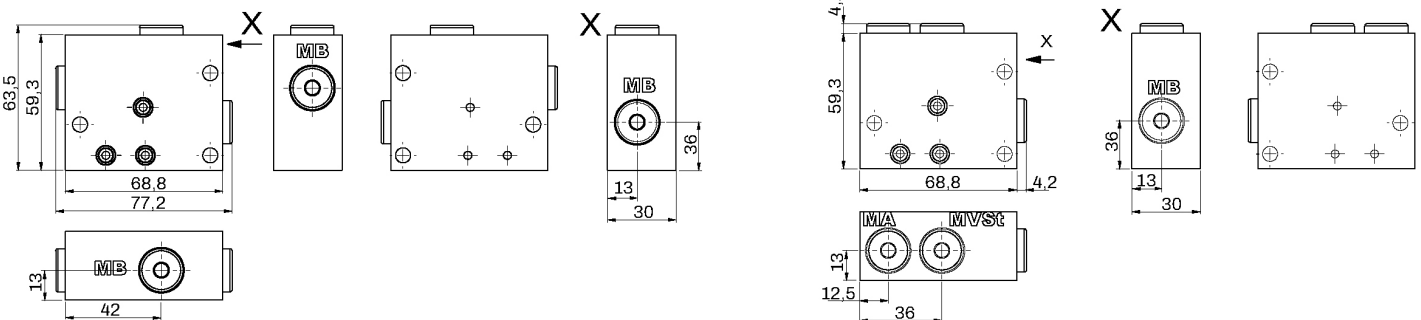

9 Notes, Standards and Safety Instructions

9.1 General Instructions

- The views in drawings are shown in accordance with the European normal projection variant
- A comma (,) is used as a decimal point in drawings
- All dimensions are given in mm

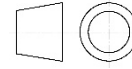

9.2 Standards

The following standards are to be observed because of the surface temperatures on the valve:

- EN 563, Temperatures on surfaces that can be touched.
- EN 982, Safety-technical requirements for fluid-technical systems and their components.

9.3 Safety requirements

- WESSEL-HYDRAULIK GmbH guarantees utilization of standard and proven safety principles in accordance with ISO 13849-2: 2003, Tables C.1 and C.2 for the construction of the valve described here.
- WESSEL-HYDRAULIK GmbH has a certified quality management system in accordance with DIN EN ISO 9001.
- The MTTFd value can be adopted from machine manufacturers with 150 years of experience for the described valve!
- Note: The user is therefore responsible for complying with the fundamental and proven safety principles according to ISO 13849-2: 2003, Tables C.1 and C.2 for the implementation and operation of the hydraulic component!

10 Accessories

See sheet 001.550.764.1