

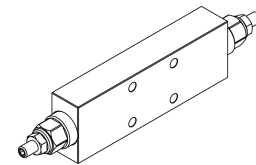

## 1 Technical Description

body material	zinc plated steel
capacity	40 lpm (10 gpm)
ports size	V1, V2: G1/4 - C1, C2: Ø7
max operating pressure	350 bar (5000 psi)
pilot ratio	4:1
maximum setting	420 bar (6100 psi)
minimum setting	60 bar (870 psi)
Pressure setting established @	cracking pressure (1in3/min)
maximum valve leakage at reseal	5 drops /minute
operating characteristic	standard
reseal	>80%
maximum recommended load pressure at maximum setting	330 bar (4800 psi)
valve weight	1,2 kg
external component surface treatment	zinc plating + sealing
temperature range	-30 to 100°C (-22 to 212°F) with BunaN seals
fluids	Mineral-based or synthetics with lubricating properties at viscosities of 10 to 500 mm/s (cSt)
filtration	Nominal value max. 10µm (NAS 8) / ISO 4406 19/17/14

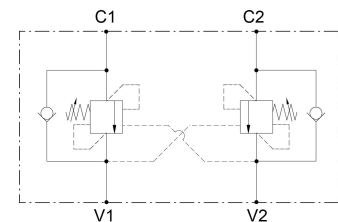

### Characteristics

- G $\frac{1}{4}$  ports
- Adjustable
- Low losses
- leakage free

- Backpressure at port 2 adds to the effective relief setting at a ratio of 1 plus the pilot ratio times the backpressure
- Set your counterbalance valve at least 1.3 times the maximum load induced pressure
- Indicated Reseat value is obtained with valve set @ maximum setting
- For customized settings and for settings from 360 bar to 420 bar please consult factory
- For special ports please consult factory

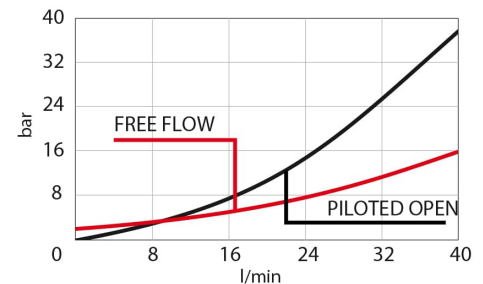

## 2 Type Code

V | A | L | - | S | N | D | 7 | 9 | 2 | 0 | 4 | G | 1 | 4 | - |   | - | 0 | 0 | 0

### Adjustable Setting

Spring **M** = 60 - 210bar  
Standard Setting 200 bar

Spring **D** = 110 - 350bar  
Standard Setting 350bar

## 3 Dimensions

pressure increase per turn	Spring M: 103 bar/turn Spring D: 171,5 bar/turn
adjustment screw internal hex size	4
seal-lock hex size	13
seal-lock torque	12-15 Nm (9-11 lbf ft)

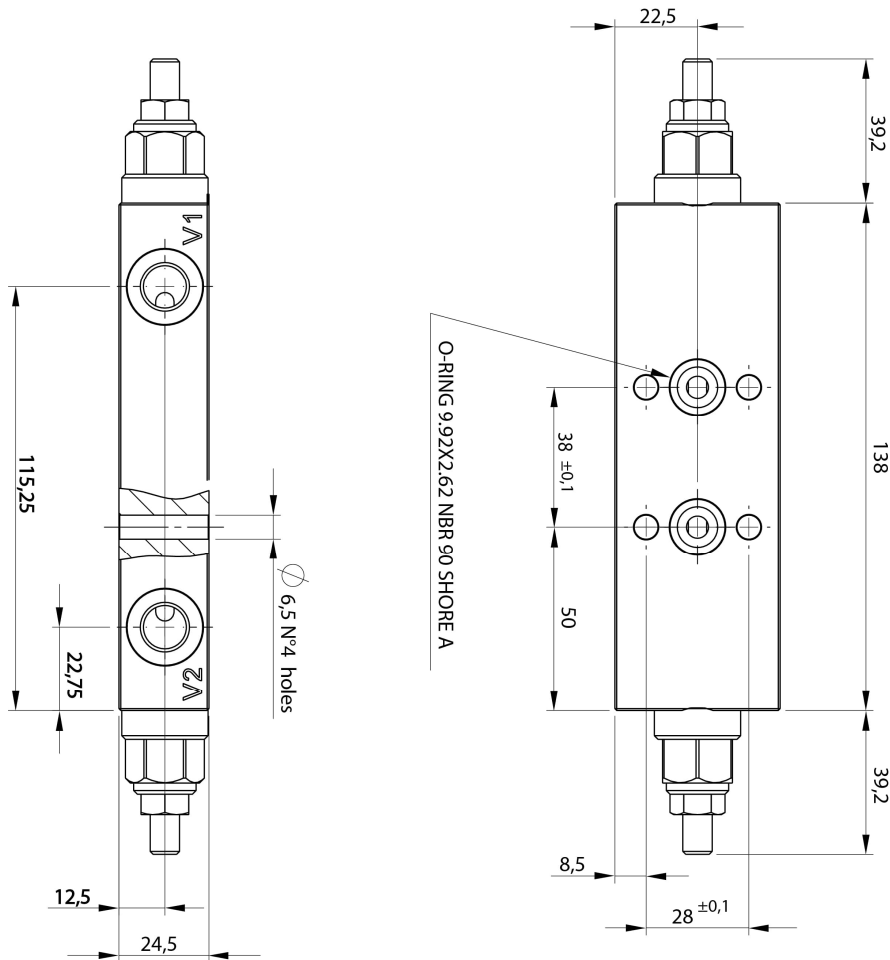

## 4 Notes, Standards and Safety Requirements

### 4.1 General remarks

- The views in drawings are shown in accordance with the European normal projection variant
- A comma ( , ) is used as a decimal point in drawings
- All dimensions are given in mm



### 4.2 Standards

The following standards are to be observed because of the surface temperatures on the load control valve:

- EN 563, Temperatures on surfaces that can be touched.
- EN 982, Safety-technical requirements for fluid-technical systems and their components.